

No. 6204K1HA-001

Single clamping bracket

Hydraulic unlocking.
 Pneumatic blow-out.
 Opening operating pressure: min. 50 bar - max. 60 bar.
 Clamping modules' contact surface: Steel, stainless and hardened.
 Base plate: Steel, unhardened.
 Repetition accuracy < 0.005 mm.



Order no.	Size	Pull-in/locking force up to [kN]	Holding force* [kN]	Blow out	S [mm]	Weight [Kg]
428060	K10.2	10	25	●	150	32
428086	K10.2	10	25	●	200	38
428102	K10.2	10	25	●	240	42

Design:

Hydraulic clamping bracket for set-up-time-optimised clamping on K10.2 clamping stations. Installation clamping module K10.2 with quadruple indexing. Pull-studs installed underneath. The pitch spacing is 200 mm. The quick-coupling plug is pre-mounted, and the integrated blow-out function can be individually connected.

Note:

* Please observe the installation instructions.

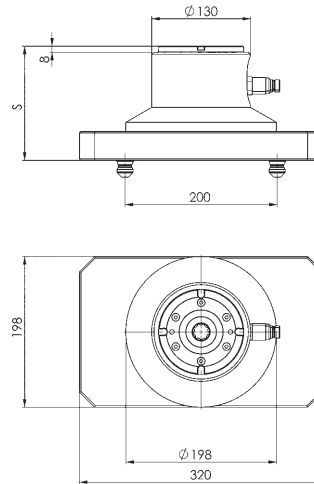

No. 6204K1HA-004

Single clamping bracket

Hydraulic unlocking.
 Pneumatic blow-out.
 Opening operating pressure: min. 50 bar - max. 60 bar.
 Clamping modules' contact surface: Steel, stainless and hardened.
 Base plate: Steel, unhardened.
 Repetition accuracy < 0.005 mm.



Order no.	Size	Pull-in/locking force up to [kN]	Holding force* [kN]	Blow out	S [mm]	Weight [Kg]
428128	K10.2	10	25	●	150	45
428144	K10.2	10	25	●	200	50
428169	K10.2	10	25	●	240	54

Design:

Hydraulic clamping bracket for set-up-time-optimised clamping on K10.2 clamping stations. Installation clamping module K10.2 with quadruple indexing. Pull-studs installed underneath. The pitch spacing is 200 mm. The quick-coupling plug is pre-mounted, and the integrated blow-out function can be individually connected.

Note:

* Please observe the installation instructions.

