

CW 1000 V2

Compact Height

BMW B2 4005	FORD W-DX35-6204	PSA E24.54.815.G
MB B8 3180 220 000 004		
VW 39D 997		

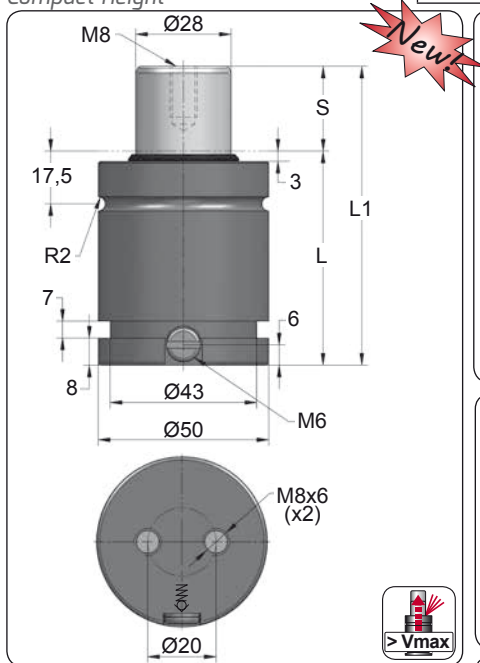

ORDER	S (mm)	L1 ±0,25 (mm)	L (mm)	Kg.
CW 1000 013 V2	13	64	51	0.55
CW 1000 016 V2	16	70	54	0.57
CW 1000 019 V2	19	76	57	0.60
CW 1000 025 V2	25	88	63	0.65
CW 1000 032 V2	32	102	70	0.70
CW 1000 038 V2	38	114	76	0.75
CW 1000 050 V2	50	138	88	0.86
CW 1000 063 V2	63	164	101	0.96
CW 1000 075 V2	75	188	113	1.06
CW 1000 080 V2	80	198	118	1.11
CW 1000 100 V2	100	238	138	1.27
CW 1000 125 V2	125	288	163	1.48

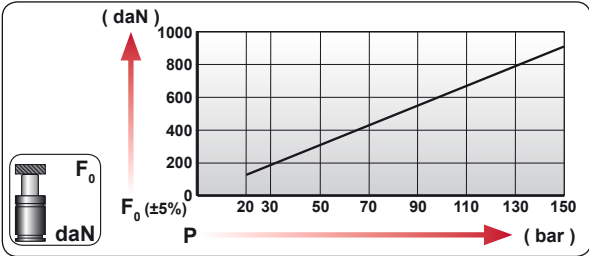

CODE	Pressure (bar)	Pressure (psi)	Force F0 (daN)	Force F1 (daN)
CW 1000 050 V2	150	2175	920	1600
CW-H 1000 050 V2	0	0	---	---

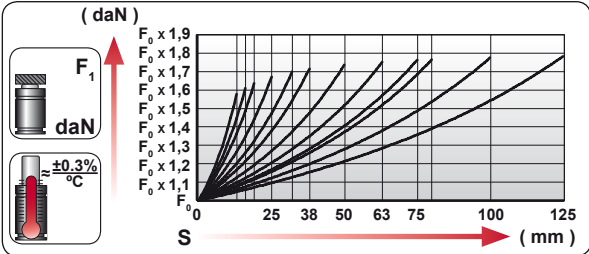

ENG ORDER
 DEU BESTELLUNG
 FRA COMMANDE
 ITA ORDINE
 ESP PEDIDO
 POR PEDIDO

CW 1000 50
CW 1000 050 V2

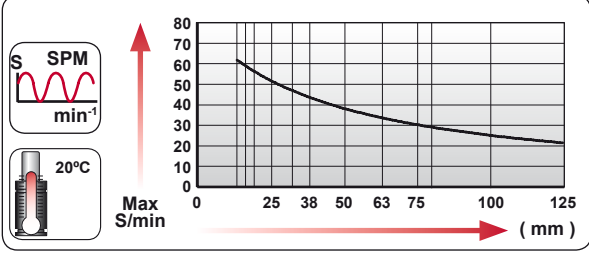



N ₂	Smax < 90%	Vmax 1,6 m/s	bar psi	bar psi	°C °F	°C °F	600 CP-
			20 290	150 2175	0 32	80 176	

	L1=131 L1=138 L1=152	L1=138	L1=138 L1=150 L1=150	L1=170 L1=185 L1=195	L1=195	L1=165 L1=175	L1=220	
MODEL	X CR 1000 CW 1000 KZ 1000	AS 1000	CT 750 CK 1000 FD 750	GN 750 CM 1000 CD 1000	AG 750	CPH 1700 CP 2000	CS 1800	
SERIES	MINI 	COMPACT HEIGHT 	THREADED 	LOW PROFILE 	HEAVY DUTY 	ISO 	HEAVY LOAD 	POWER COMPACT STROKE

CW



KRM6  **BK** 

CWC

DRM8



TNRR



9RM8



MCRR



7RM8



TFRR



SKK



SGS









SEAL KIT S-XXXXXXX

CARTRIDGE KIT C-XXXXXXX





CODE	CW 1000 050 V2	KIT S-XXXXXXX KIT C-XXXXXXX	A14-050	06 CG 2-Q
ENG ORDER	GAS SPRING	REPAIR KIT	FLANGE	CHARGING ADAPTER
DEU BESTELLUNG	GASDRUCKFEDER	ERSATZTEILSATZ	FLANSCHEN	LADEADAPTER
FRA COMMANDE	RESSORT À GAZ	KIT DE RÉPARATION	BRIDE	RACCORD DE CHARGE
ITA ORDINE	CILINDRO AD AZOTO	KIT DI MANUTENZIONE	FLANGE	ADATTATORE DI CARICO
ESP PEDIDO	RESORTE DE GAS	KIT DE REPARACION	BRIDA	ADAPTADOR DE CARGA
POR PEDIDO	CILINDRO DE GÁS	KIT DE MANUTENÇÃO	FLANGE	ADAPTADOR DE CARGA

CWC 1000 V2 MOUNTS

Compact Height

AZOL
GAS

A14-050

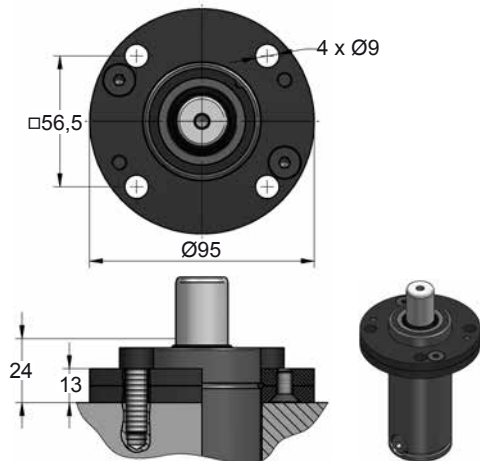

A34-050

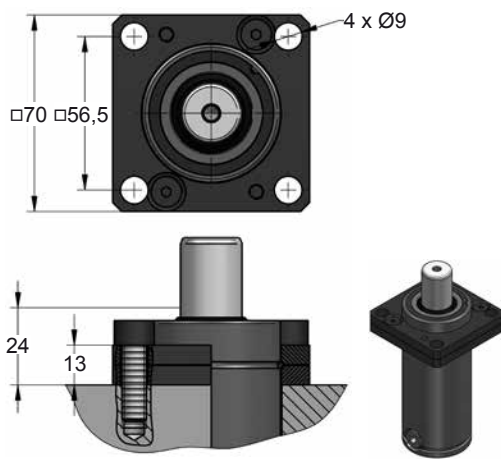

B36-050

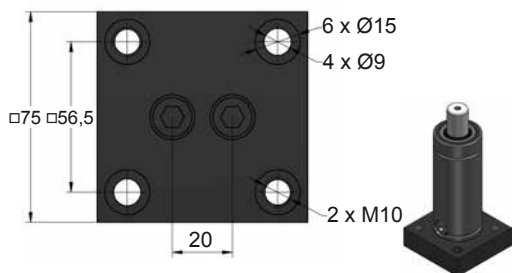
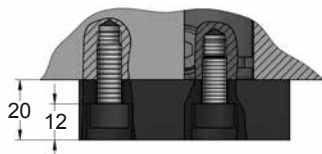

B41-050

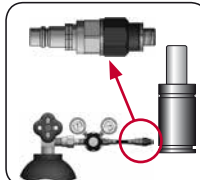
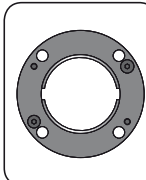
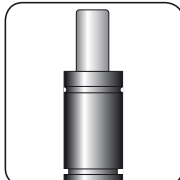
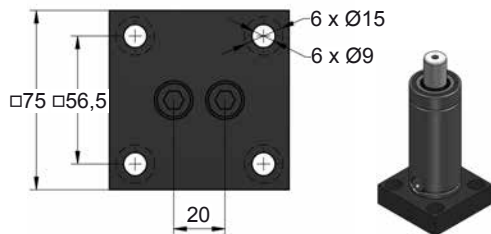
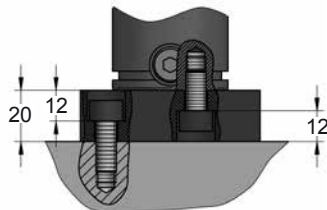

CODE	CWC 1000 050 V2	KIT S-XXXXXXX KIT C-XXXXXXX	A14-050	18 CG 1-Q	
ENG	ORDER	GAS SPRING	REPAIR KIT	FLANGE	CHARGING ADAPTER
DEU	BESTELLUNG	GASDRUCKFEDER	ERSATZTEILSATZ	FLANSCH	LADEADAPTER
FRA	COMMANDE	RESSORT À GAZ	KIT DE RÉPARATION	BRIDE	RACCORD DE CHARGE
ITA	ORDINE	CILINDRO AD AZOTO	KIT DI MANUTENZIONE	FLANGE	ADATTATORE DI CARICO
ESP	PEDIDO	RESORTE DE GAS	KIT DE REPARACION	BRIDA	ADAPTADOR DE CARGA
POR	PEDIDO	CILINDRO DE GÁS	KIT DE MANUTENÇÃO	FLANGE	ADAPTADOR DE CARGA



CWC 1000 V2 MOUNTS

Compact Height

C05-050

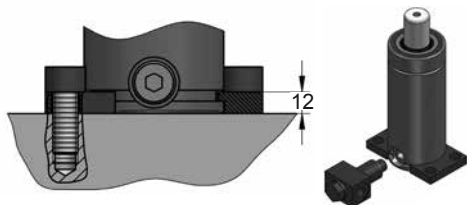
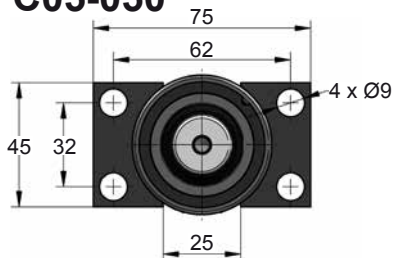

C20-050

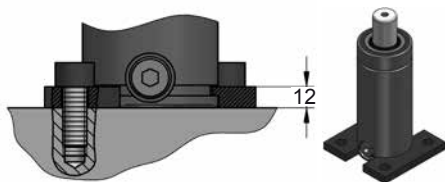
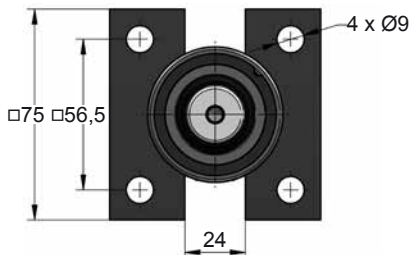

D02-050

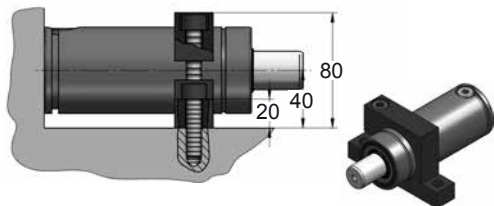
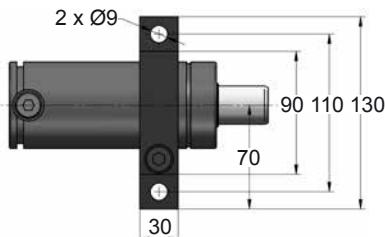

D67-050

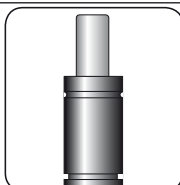
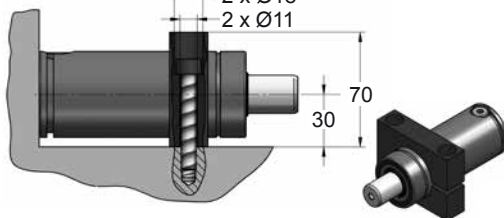
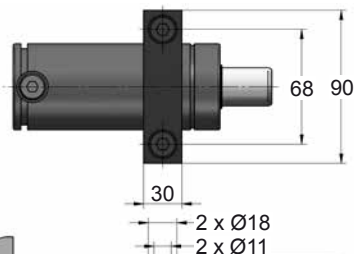

SEAL
KIT S-XXXXXXX

CARTRIDGE
KIT C-XXXXXXX

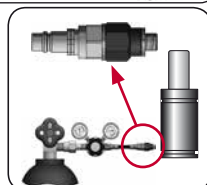
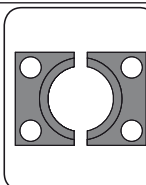

CODE	CWC 1000 050 V2	KIT S-XXXXXXX KIT C-XXXXXXX	C05-050	18 CG 1-Q	
ENG	ORDER	GAS SPRING	REPAIR KIT	FLANGE	CHARGING ADAPTER
DEU	BESTELLUNG	GASDRUCKFEDER	ERSATZTEILSATZ	FLANSCHEN	LADEADAPTER
FRA	COMMANDE	RESSORT À GAZ	KIT DE RÉPARATION	BRIDE	RACCORD DE CHARGE
ITA	ORDINE	CILINDRO AD AZOTO	KIT DI MANUTENZIONE	FLANGE	ADATTATORE DI CARICO
ESP	PEDIDO	RESORTE DE GAS	KIT DE REPARACION	BRIDA	ADAPTADOR DE CARGA
POR	PEDIDO	CILINDRO DE GÁS	KIT DE MANUTENÇÃO	FLANGE	ADAPTADOR DE CARGA