

VAM 3000

Speed Control

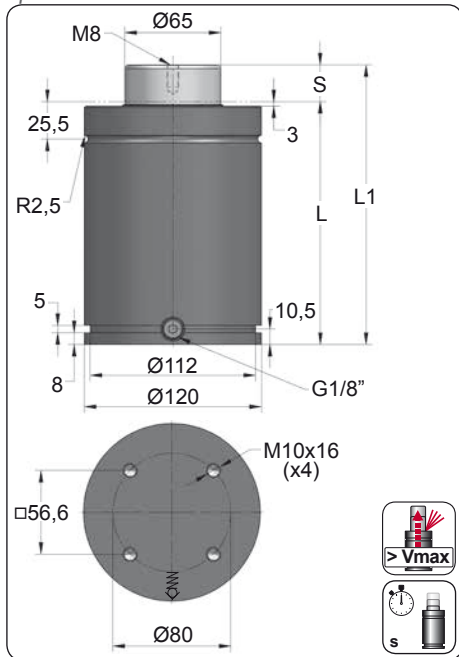

ORDER	S (mm)	L1 ±0,25 (mm)	L (mm)	Kg.
VAM 3000 012	12.7	165.4	152.7	10.39
VAM 3000 025	25	190	165	11.04
VAM 3000 038	38	216	178	11.73
VAM 3000 050	50	240	190	12.37
VAM 3000 063	63.5	267	203.5	13.08
VAM 3000 080	80	300	220	13.96
VAM 3000 100	100	340	240	15.02
VAM 3000 125	125	390	265	16.34

$t_{max} = k \times S \times U$

Max. delay time (t_{max})
Constant (k)
Stroke used (S_U)

VAM 3000	k
	0.131

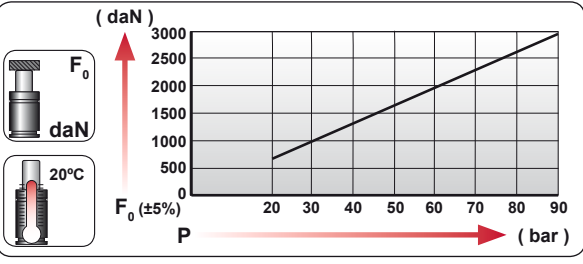

CODE	Pressure		Force	
	bar	psi	daN	daN
VAM 3000	90	1305	2985	4080

-Slight initial return back depends on the stroke used.
-Return at constant slowed speed.

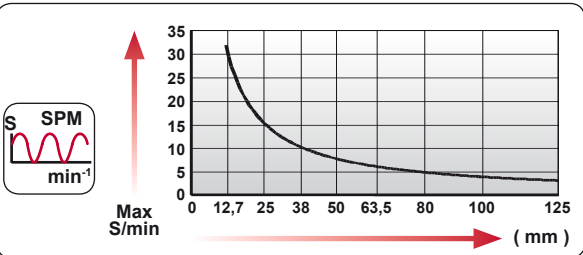
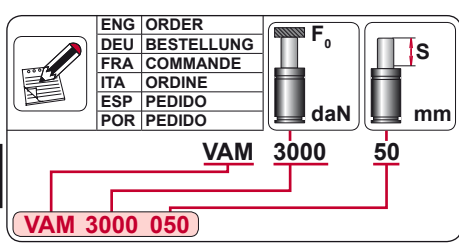
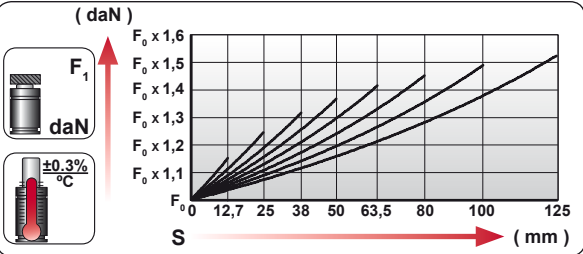

N₂

S_{max} < 90%

V_{max} 0,5 m/s

P_{min} (20°C)
P_{max} (20°C)

T_{min}
T_{max}

600 CP-

N ₂	S _{max} < 90%	V _{max} 0,5 m/s	bar psi	bar psi	°C °F	°C °F	600 CP-
			20 290	90 1305	0 32	80 176	

CONVENTIONAL

Stroke

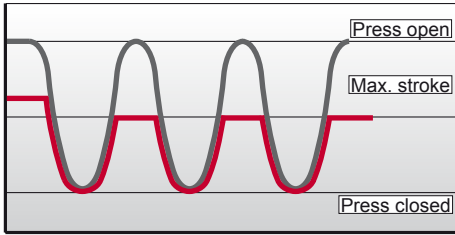

Time

VAM

Stroke

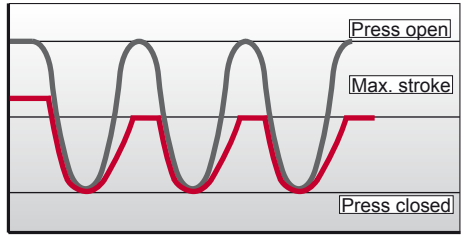

Time

DATA REQUIRED



• Desired force (daN) :



• Total stroke (mm) :



• Stroke used (mm) :



• Number of cycles per minute :



• Desired delay time (eg. 1 second) :

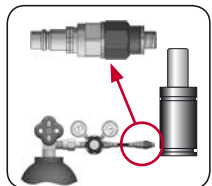
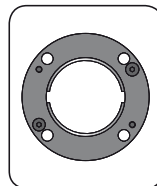
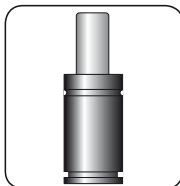

CODE	VAM 3000 050	KIT S-XXXXXXX KIT C-XXXXXXX	A14-120	18 CG 1-Q
ENG	ORDER	REPAIR KIT	FLANGE	CHARGING ADAPTER
DEU	BESTELLUNG	ERSATZTEILSATZ	FLANSCH	LADEADAPTER
FRA	COMMANDE	KIT DE RÉPARATION	BRIDE	RACCORD DE CHARGE
ITA	ORDINE	KIT DI MANUTENZIONE	FLANGE	ADATTATORE DI CARICO
ESP	PEDIDO	KIT DE REPARACION	BRIDA	ADAPTADOR DE CARGA
POR	PEDIDO	KIT DE MANUTENÇÃO	FLANGE	ADAPTADOR DE CARGA

VAM 3000 MOUNTS

Speed Control

AZOL
GAS

A14-120

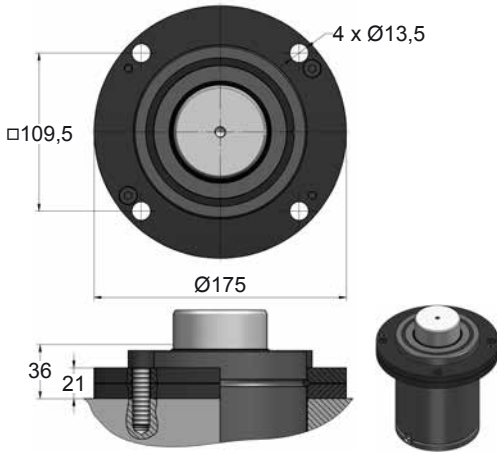

A34-120

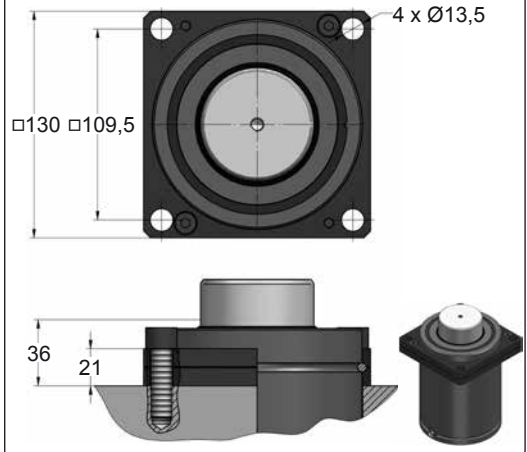

B21-120

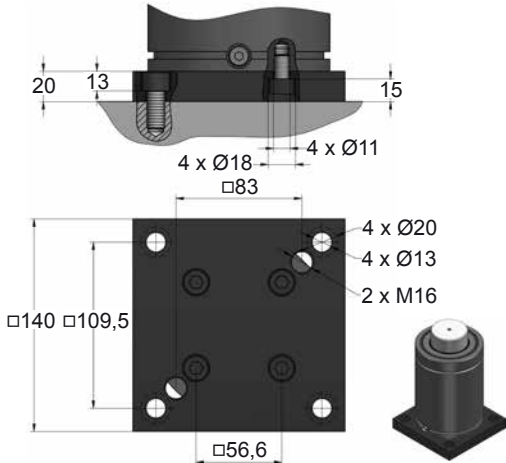

B76-120

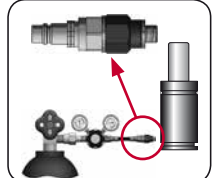
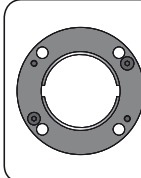
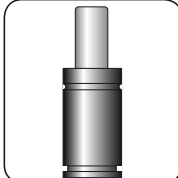
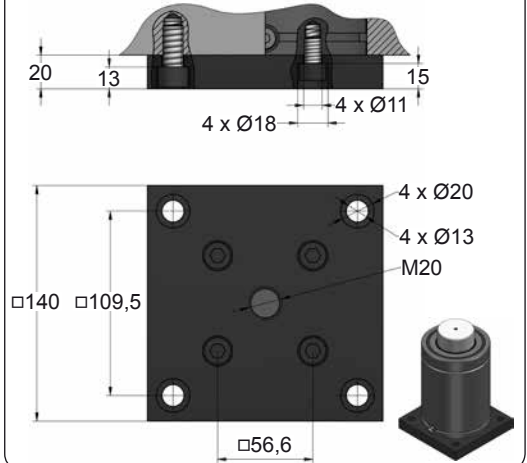

CODE	VAM 3000 050	KIT S-XXXXXXX KIT C-XXXXXXX	A14-120	18 CG 1-Q
ENG ORDER	GAS SPRING	REPAIR KIT	FLANGE	CHARGING ADAPTER
DEU BESTELLUNG	GASDRUCKFEDER	ERSATZTEILSATZ	FLANSCHEN	LADEADAPTER
FRA COMMANDE	RESSORT À GAZ	KIT DE RÉPARATION	BRIDE	RACCORD DE CHARGE
ITA ORDINE	CILINDRO AD AZOTO	KIT DI MANUTENZIONE	FLANGE	ADATTATORE DI CARICO
ESP PEDIDO	RESORTE DE GAS	KIT DE REPARACION	BRIDA	ADAPTADOR DE CARGA
POR PEDIDO	CILINDRO DE GAS	KIT DE MANUTENÇÃO	FLANGE	ADAPTADOR DE CARGA



VAM 3000 MOUNTS

Speed Control

C05-120

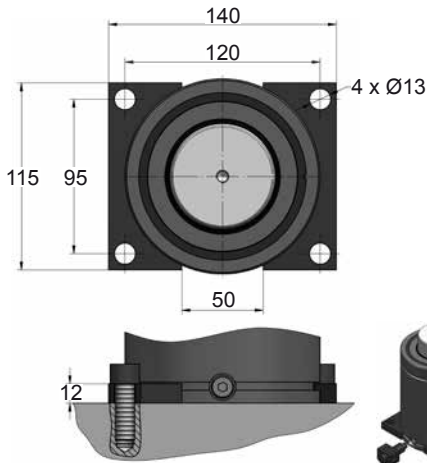

C20-120

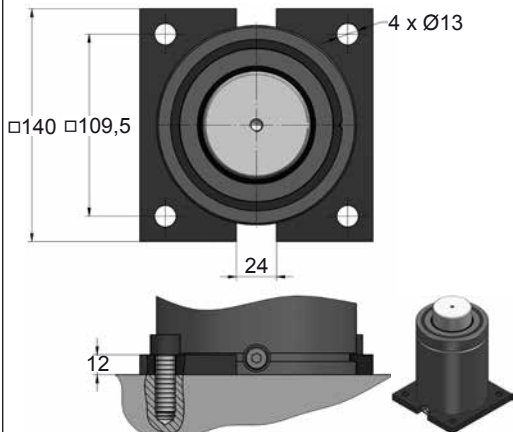

D02-120

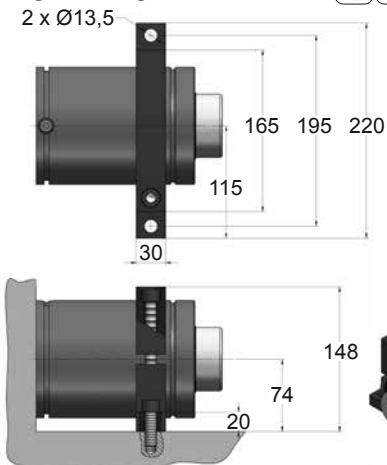

D67-120

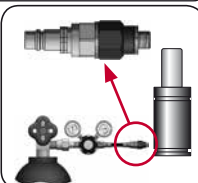
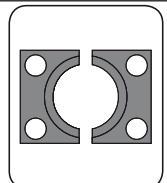
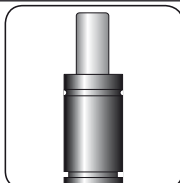
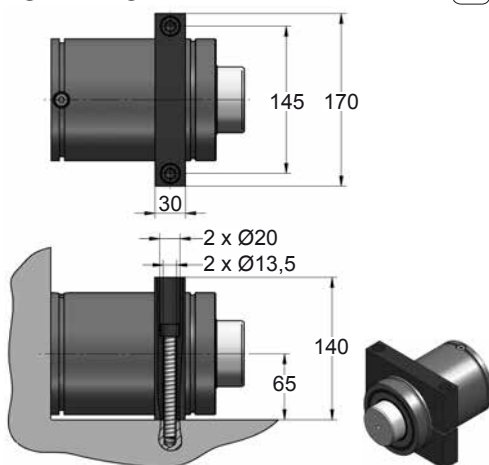

CODE	VAM 3000 050	KIT S-XXXXXXX KIT C-XXXXXXX	C05-120	18 CG 1-Q
ENG ORDER	GAS SPRING	REPAIR KIT	FLANGE	CHARGING ADAPTER
DEU BESTELLUNG	GASDRUCKFEDER	ERSATZTEILSATZ	FLANSCHEN	LADEADAPTER
FRA COMMANDE	RESSORT À GAZ	KIT DE RÉPARATION	BRIDE	RACCORD DE CHARGE
ITA ORDINE	CILINDRO AD AZOTO	KIT DI MANUTENZIONE	FLANGE	ADATTATORE DI CARICO
ESP PEDIDO	RESORTE DE GAS	KIT DE REPARACION	BRIDA	ADAPTADOR DE CARGA
POR PEDIDO	CILINDRO DE GÁS	KIT DE MANUTENÇÃO	FLANGE	ADAPTADOR DE CARGA