

FÖRDERBAND, ELEKTRISCH

2195.301.

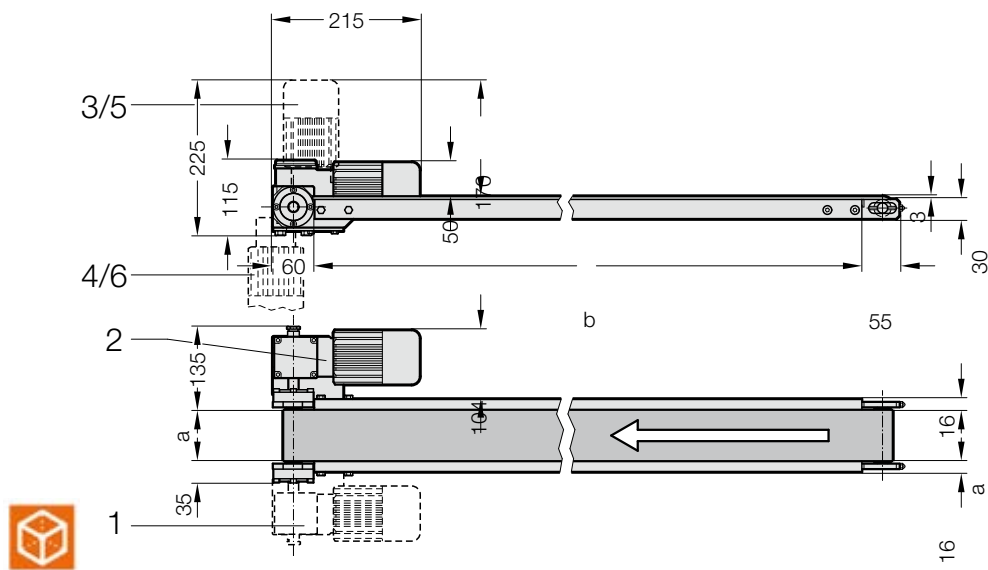

2195.301. Förderband, elektrisch

b	500	750	1.000	1.250	1.500	1.750	2.000	2.250	2.500
a									
30	●	●	●	●	●	●	●	●	●
50	●	●	●	●	●	●	●	●	●
75	●	●	●	●	●	●	●	●	●
100	●	●	●	●	●	●	●	●	●
125	●	●	●	●	●	●	●	●	●
150	●	●	●	●	●	●	●	●	●
175	●	●	●	●	●	●	●	●	●
200	●	●	●	●	●	●	●	●	●
225	●	●	●	●	●	●	●	●	●
250	●	●	●	●	●	●	●	●	●
275	●	●	●	●	●	●	●	●	●
300	●	●	●	●	●	●	●	●	●

Bandbelastung:

Bandbreite a	kg je lfd. m
30–50–75	4
100–125–150	7
175–200–225	10
250–275–300	15

Weitere Informationen siehe Beschreibung und Bestell-Richtlinien.

Bestell-Beispiel:

Förderband, elektrisch	= 2195.
Typ 301	= 301.
Bandbreite a = 100 mm	= 100.
Nennbandlänge b = 1750 mm	= 1750.
Bandgeschwindigkeit	= 1
Motor 400 V	= 3
Motorlage	= 1
Motorsteuerung	= 1
Bestell-Nr.	= 2195.301. 100. 1750. 1 3 1 1