

电动输送带

2195.401.

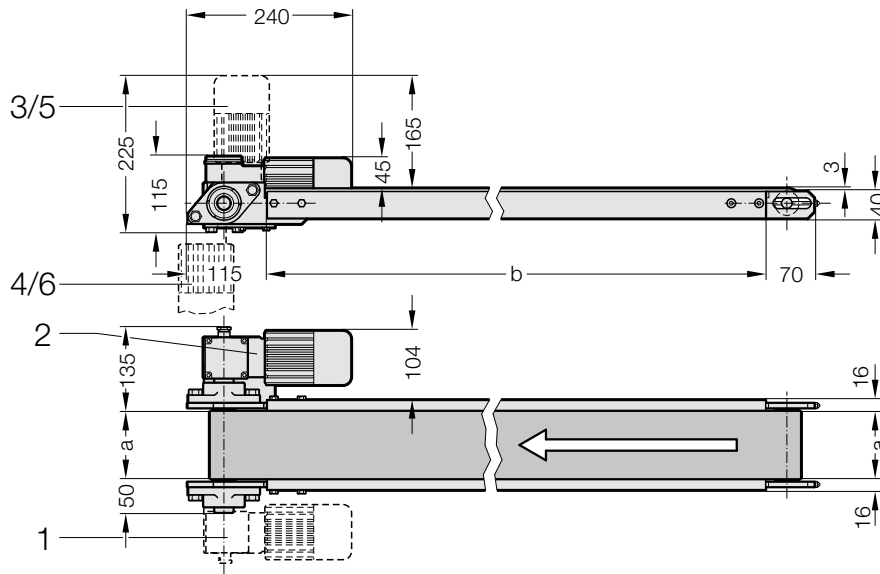

2195.401. 电动输送带

b	500	750	1,000	1,250	1,500	1,750	2,000	2,250	2,500
a									
30	●	●	●	●	●	●	●	●	●
50	●	●	●	●	●	●	●	●	●
75	●	●	●	●	●	●	●	●	●
100	●	●	●	●	●	●	●	●	●
125	●	●	●	●	●	●	●	●	●
150	●	●	●	●	●	●	●	●	●
175	●	●	●	●	●	●	●	●	●
200	●	●	●	●	●	●	●	●	●
225	●	●	●	●	●	●	●	●	●
250	●	●	●	●	●	●	●	●	●
275	●	●	●	●	●	●	●	●	●
300	●	●	●	●	●	●	●	●	●

带负载:

带宽 a 千克每延米

30-50-75	5
100-125-150	10
175-200-225	14
250-275-300	17

更多信息, 请参见说明书和订购指南。

订购示例:

电动输送带	= 2195.
型号 401	= 401.
带宽 a = 100 mm	= 100.
额定带长 b = 1750 mm	= 1750.
输送带速度	= 1
电机 400 v	= 3
电机位置	= 1
电机控制装置	= 1
订购号	= 2195.401. 100. 1750. 1 3 1 1