

PÁSOVÝ DOPRAVNÍK, ELEKTRICKÝ

2195.401.

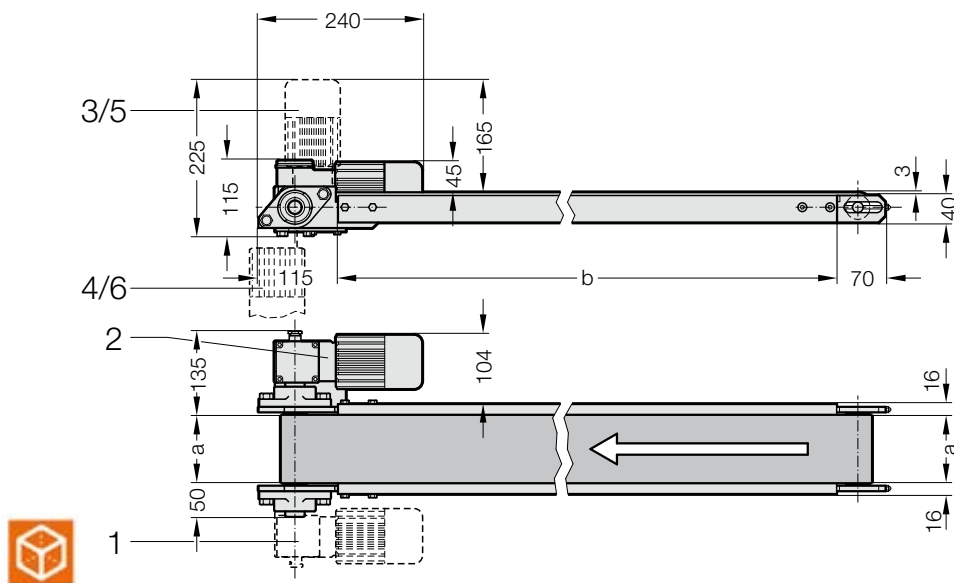

2195.401. Pásový dopravník, elektrický

b	500	750	1 000	1 250	1 500	1 750	2 000	2 250	2 500
a									
30	●	●	●	●	●	●	●	●	●
50	●	●	●	●	●	●	●	●	●
75	●	●	●	●	●	●	●	●	●
100	●	●	●	●	●	●	●	●	●
125	●	●	●	●	●	●	●	●	●
150	●	●	●	●	●	●	●	●	●
175	●	●	●	●	●	●	●	●	●
200	●	●	●	●	●	●	●	●	●
225	●	●	●	●	●	●	●	●	●
250	●	●	●	●	●	●	●	●	●
275	●	●	●	●	●	●	●	●	●
300	●	●	●	●	●	●	●	●	●

Zatížení pásu:

Šířka pásu a kg na běž. m

30–50–75	5
100–125–150	10
175–200–225	14
250–275–300	17

Další informace viz popis a směrnice pro objednání.

Příklad objednávky:

Pásový dopravník, elektrický	= 2195.
Typ 401	= 401.
Šířka pásu a = 100 mm	= 100.
Nominální délka pásu b = 1750 mm	= 1750.
Rychlost pásu	= 1
Motor 400 V	= 3
Poloha motoru	= 1
Řízení motoru	= 1
Objednací číslo	= 2195.401. 100. 1750. 1 3 1 1