

CONVEYOR BELT, ELECTRICALLY CONTROLLED

2195.401.

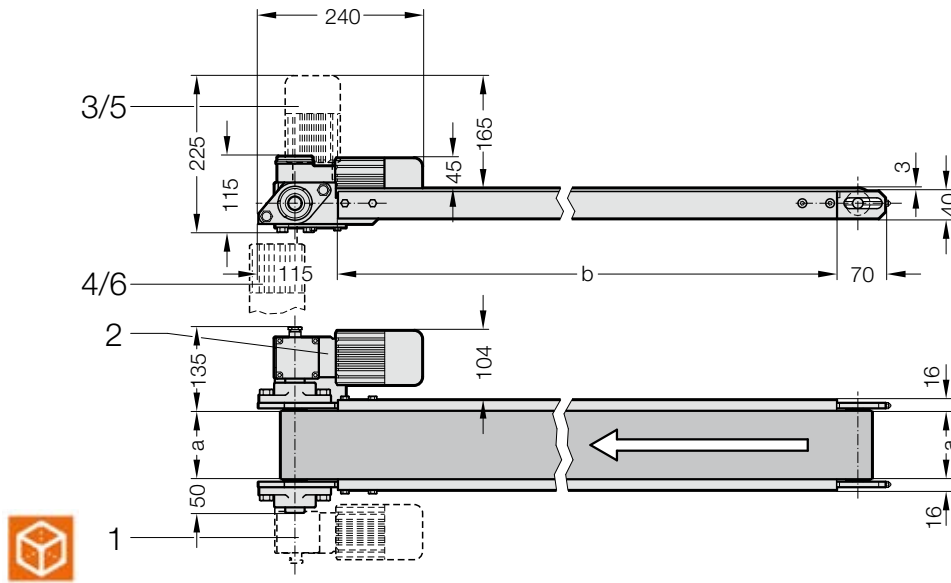

2195.401. Conveyor belt, electrically controlled

b	500	750	1,000	1,250	1,500	1,750	2,000	2,250	2,500
a									
30	●	●	●	●	●	●	●	●	●
50	●	●	●	●	●	●	●	●	●
75	●	●	●	●	●	●	●	●	●
100	●	●	●	●	●	●	●	●	●
125	●	●	●	●	●	●	●	●	●
150	●	●	●	●	●	●	●	●	●
175	●	●	●	●	●	●	●	●	●
200	●	●	●	●	●	●	●	●	●
225	●	●	●	●	●	●	●	●	●
250	●	●	●	●	●	●	●	●	●
275	●	●	●	●	●	●	●	●	●
300	●	●	●	●	●	●	●	●	●

Belt load:

Belt width a	kg per meter conveyed
30- 50- 75	5
100-125-150	10
175-200-225	14
250-275-300	17

For more information refer to description and ordering guidelines.

Ordering Code (example):

Conveyor belt, electrically controlled	= 2195.
Typ 401	= 401.
Belt width	a = 100 mm = 100.
Nominal belt length	b = 1750 mm = 1750.
Belt speed	= 1
Motor voltage 400 V	= 3
Motor position	= 1
Motor controller	= 1
Order No.	= 2195.401. 100. 1750. 1 3 1 1