

快速更换型冲头，凸模切削刃直径大于凸模柄部直径，圆形，重载荷用

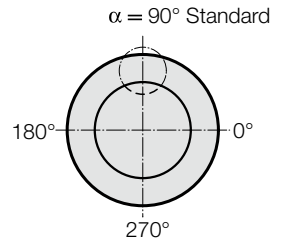

2215.

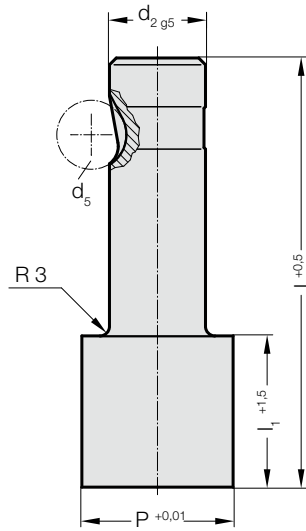

2215. 快速更换型冲头，凸模切削刃直径大于凸模柄部直径，圆形，重载荷用

d <sub>2</sub> / 订购数字	d <sub>5</sub>	P	l <sub>1</sub> / 订购数字	l (订货字母)	80 (E)	90 (F)	100 (G)
13 / (3)	12	13,1 - 32	19(2) 30(4)		●	●	●
16 / (4)	12	16,1 - 38	19(2) 30(4)		●	●	●
20 / (5)	12	20,1 - 40	19(2) 30(4)		●	●	●
25 / (6)	12	25,1 - 44	19(2) 30(4)		●	●	●
32 / (7)	12	32,1 - 50	19(2) 30(4)		●	●	●
40 / (9)	12	40,1 - 56	19(2) 30(4)		●	●	●

材料:

HSS  
硬度 62 ± 2 HRC

结构:

精磨凸模柄部和凸模切削刃直径。  
特别尺寸请洽询

订购示例:

2 2 1 5 . 7 G 2 . 3 2 1 0

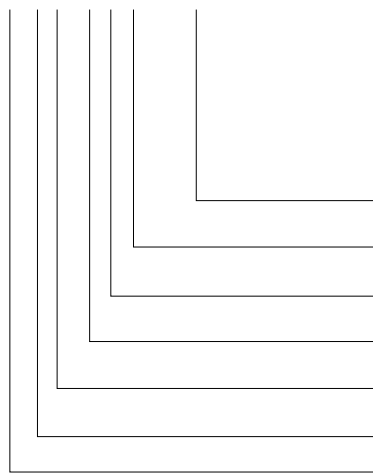

形状: 圆形  
P = ∅ 32,1 mm  
冲裁凸模长度: l<sub>1</sub>  
19 mm  
长度: l  
100 mm  
直径: d<sub>2</sub>  
32 mm  
型号:  
切削刃刃较大、重型  
规格:  
圆形  
冲头:  
无弹顶销

= 3210  
订购数字  
= (2)  
订货字母  
= (G)  
订购数字  
= (7)  
订购数字  
= (5)  
订购数字  
= (1)  
= 22