

ELECTRIC TRANSPORTER, CLEAN LINE

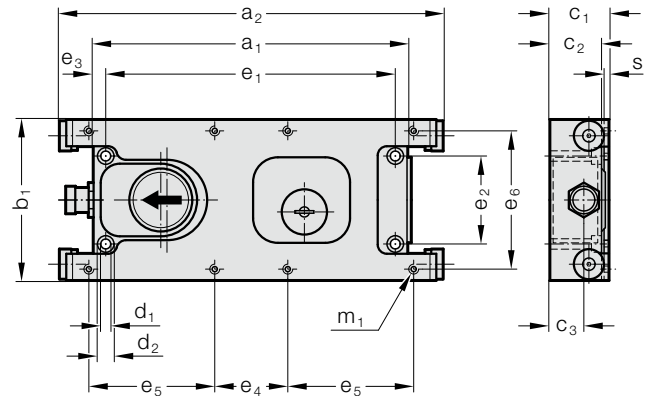

2299.61.1□100.



Description:

The electric transporter simplifies automation, increases energy efficiency and reduces noise pollution. The speed can be adjusted mechanically and, depending on the task type, the transporter conveys, sorts or separates electrically.

Used predominantly in the food and pharmaceutical industries.

Material:

made from stainless steel and anodised aluminium

Order example:

Order numbers for CLEAN LINE electric transporter, **without connection cable** (2299.60.82.0x.xx)

with control unit, 230 V

- 2299.61.18100.01 MINI
- 2299.61.14100.01 COMPACT
- 2299.61.12100.01 MAX

Replacement **without** control unit 230 V:

- 2299.61.18100.00 MINI
- 2299.61.14100.00 COMPACT
- 2299.61.12100.00 MAX

Note:

The connection cable, control unit transporter and optionally the signal cable, control unit press are to be ordered separately. For more information on the electrical connection, control unit and guide channel, see Accessories.

Socket head screws DIN ISO 4762 stainless steel A2 for fastening the transporter are included in delivery.

2299.61. Electric transporter, CLEAN LINE

Order No	a ₁	a ₂	b ₁	c ₁	c ₂	c ₃	d ₁	d ₂	e ₁	e ₂	e ₃	e ₄	e ₅	e ₆	m ₁	s
2299.61.18100.00	220	271	118	38.7	33.5	20.9	6.3	10	206	70	7	25	107	100	M5	3
2299.61.14100.00	250	305	128	47	41	27	8.2	13.5	230	70	10	58	100	110	M6	4
2299.61.12100.00	260	316	138	68	61	38	8.2	13.5	238	70	11	58	105	110	M6	6

Execution	MINI	KOMPAKT	MAX
Transport weight max. (excl. channel) [kg]	10	20	40
Guide channel weight max. [kg]	4	8	16
Stroke	20	20	20
Conveying speed (mechanically adjustable) [m/min.]	4 - 8	4 - 8	4 - 8
Warning system (motion sensor)	integrated	integrated	integrated
Start/stop	Controllable via PLC	Controllable via PLC	Controllable via PLC
Motor and overload protection	integrated	integrated	integrated
Noise emissions [dB-A]	60	60	60
Power consumption [kW]	0.05	0.07	0.15
Electrical connection, control unit	M23	M23	M23
Protection type	IP66	IP66	IP66
Weight [kg]	2.65	3.7	6.3
Temperature range (permissible ambient temperature)	-20 to +100 °C	-20 to +100 °C	-20 to +100 °C

TRANSPORTER ELECTRICAL - ACCESSORIES

CONTROL UNIT CLEAN LINE, SIGNAL CABLE, CONNECTION CABLE

2299.61.1 □ 100.12

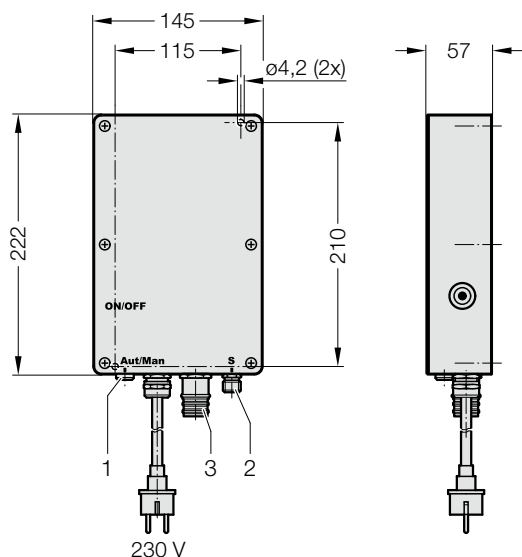

Description:

The control unit is the electrical module for controlling the transporter.

Material:

Aluminium die casting
IP67

Technical data:

Temperature operating range: -20 to +40 °Celsius (environment temperature)

Note:

The control unit must be mounted on a metal surface for heat dissipation. Before connecting the electric transporter, check that the channel can move freely in the direction of travel.

Included in the delivery,

Mains connection incl. plugs for USA and GB,

Fixing bolts DIN EN ISO 4762 M4 x 20 (x 2) stainless steel A2

1 - Changeover between PLC and manual operation



PLC mode:

In this position, this start/stop function is controlled via the straight signal cable (M12 plug).



Manual mode:

In this position, the start/stop function is controlled by the control unit.

2 - 2299.60.81.01. Signal cable straight, to the press order separately

Order No	l [m]
2299.60.81.01.03	3
2299.60.81.01.05	5
2299.60.81.01.10	10

For further information, see catalogue page for straight signal cable

2299.61. Control unit CLEAN LINE

Order No	Connection [V]	Power requirement [A]
2299.61.12100.12	230	1,2 - 2,2
2299.61.14100.12	230	0,75 - 1,7
2299.61.18100.12	230	0,55 - 1,3

1-phase 110-230 V, 50-60 Hz, earthed connection

3 - 2299.60.82.01. Connection cable straight/straight, control unit - transporter order separately

Order No	l [m]
2299.60.82.01.03	3
2299.60.82.01.05	5
2299.60.82.01.10	10
2299.60.82.01.15	15

2299.60.82.02. Connection cable straight/90°, control unit - transporter order separately

Order No	l [m]
2299.60.82.02.03	3
2299.60.82.02.05	5
2299.60.82.02.10	10
2299.60.82.02.15	15