

支承螺栓 止推垫圈

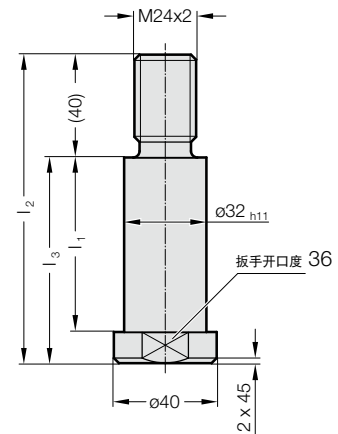

2441.18.



材料:
Nr. 1.7225, 热处理

2441.18. 支承螺栓

订购编号	l_1	l_2	l_3
2441.18.032.048	48	100	60
2441.18.032.068	68	120	80
2441.18.032.088	88	140	100
2441.18.032.108	108	160	120
2441.18.032.128	128	180	140
2441.18.032.148	148	200	160
2441.18.032.168	168	220	180
2441.18.032.188	188	240	200
2441.18.032.208	208	260	220
2441.18.032.228	228	280	240
2441.18.032.248	248	300	260
2441.18.032.268	268	320	280
2441.18.032.288	288	340	300



2441.16.

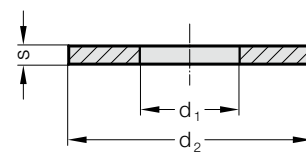

材料:
Nr. 1.0570

2441.16. 止推垫圈

订购编号	d_1	d_2	s
2441.16.330.080.06	33	80	6
2441.16.330.100.08	33	100	8