

DAMPER, LIGHT-DUTY

2450.11B.

Mounting example

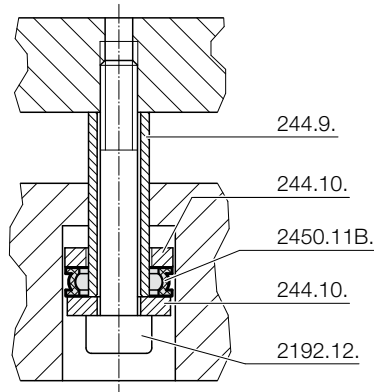
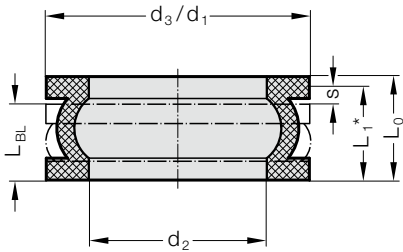

Description:

Dampers, light duty, made of co-polyester elastomer are found in the elevating units in progressive dies in the automotive and white goods industry. The increasing stresses on screws and bolts as well as noise emission are reduced by the light duty dampers. The two-ply version of the flanged damper can also be used depending on the force or stroke without the use of an additional distance washer.

Benefits:

- High absorption of force and energy
- Long service life and high level of operating safety
- Noise reduction
- High degree of effectiveness

Material:

Co-Polyester-Elastomer

Technical data:

Surroundings: Resistant to microbes, seawater, chemicals.
 No absorption of water and no swelling.
 Grease and oil resistant.
 Approved temperature range: -40 °C to +90 °C (-40 °F to +194 °F)

Note:

Socket cap screw 2192.12. see Section C
 Spacer tube 244.9. see Section F
 Washer 244.10. see Section F

2450.11B. Damper, light-duty

Order No	d ₁	d ₂	d ₃	L ₀ ****	L ₁	Stroke (s)	F _{max} [N] (static)	L _{BL}	W [Nm/stroke (s)]**	W _h [Nm/h]****
2450.11B.0300.0203.118	30	20.3	30.2	11.8	10.8	2.7	5,000	8.7	8	20000

*Dimension L₁ is the slump which must be taken into account for the design.

**W = Total energy per stroke

***W_h = Total energy per hour