

GAZLI YAY POWERLINE

Not:

150 bar da başlangıçtaki yay kuvveti = 1500 daN

Yedek parçalar için sipariş kodu: 2487.12.01500

Valfsiz gazlı yay

Sipariş No (örnek): 2487.12.01500 .P

Kullanılan gaz: Nitrojen – N₂

Maks. dolum basıncı: 150 bar

Min. dolum basıncı: 25 bar

Çalışma sıcaklığı: 0°C / +80°C

Sıcaklığa bağlı Kuvvet artışı: ± 0,3%/°C

Önerilen Strok/dk.:

yaklaşık 50 ila 100 arası (20°C de)

Maks. piston hızı: 1,6 m/s

2487.12.01500.

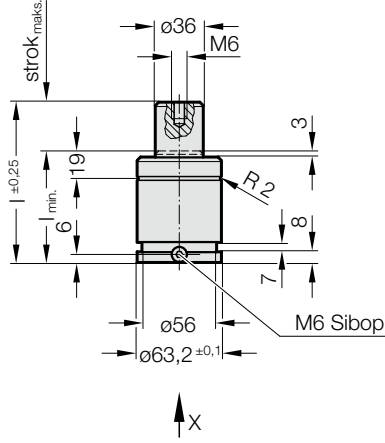

Görünüm X

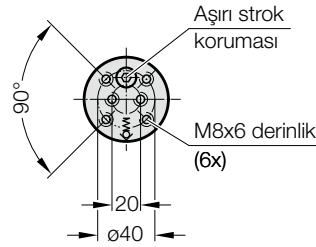

2487.12.01500.

Gazlı Yay POWERLINE

| Sipariş No. | strok _{maks.} (s) | l _{min.} | l |
|-------------------|----------------------------|-------------------|-----|
| 2487.12.01500.013 | 13 | 57 | 70 |
| 2487.12.01500.016 | 16 | 60 | 76 |
| 2487.12.01500.019 | 19 | 63 | 82 |
| 2487.12.01500.025 | 25 | 69 | 94 |
| 2487.12.01500.032 | 32 | 76 | 108 |
| 2487.12.01500.038 | 38 | 82 | 120 |
| 2487.12.01500.050 | 50 | 94 | 144 |
| 2487.12.01500.063 | 63 | 107 | 170 |
| 2487.12.01500.075 | 75 | 119 | 194 |
| 2487.12.01500.080 | 80 | 124 | 204 |
| 2487.12.01500.100 | 100 | 144 | 244 |
| 2487.12.01500.125 | 125 | 169 | 294 |

Yay başlangıç kuvveti/Basınç miktarı

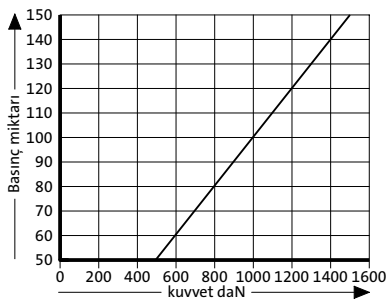

Yay kuvveti yer değişimi/Kurs artışı

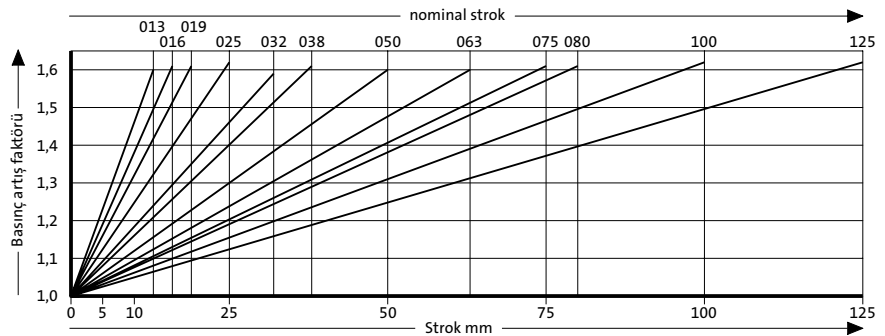

Basınç artış faktörü yer değişimini hesaba katar fakat dış etkenleri göz önünde bulundurmaz!