

冲头, 阶梯式, 正方形, 带弹顶销, ISO 8020

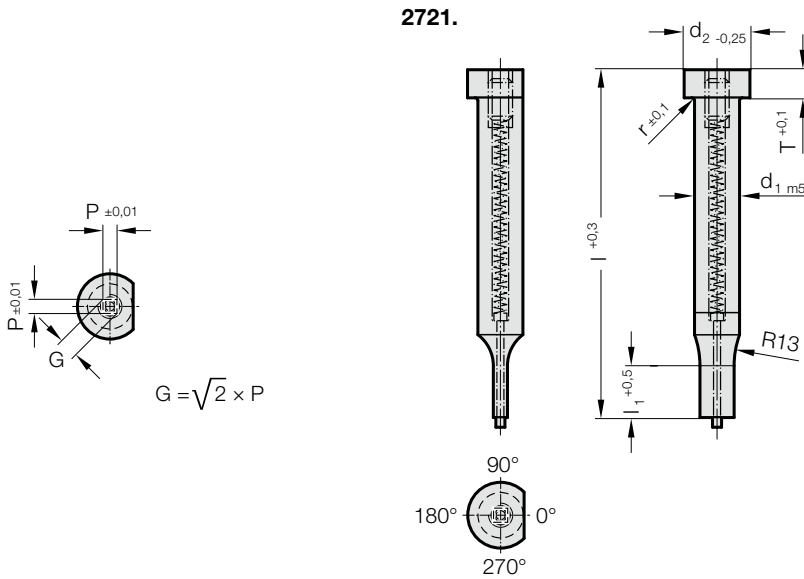

2721. 冲头, 阶梯式, 正方形, 带弹顶销, ISO 8020

d_1 / 订购数字	d_2	P_{min}	G_{max}	l_1 / 订购数字	r	T	l / (订货字母)	71 (D)	80 (E)	90 (F)	100 (G)	120 (J)
5 / (3)	8	2	4.9	13 (3) 19 (4)	0.3	5		●	●	●	●	●
6 / (4)	9	2.5	5.9	13 (3) 19 (4)	0.3	5		●	●	●	●	●
8 / (5)	11	4	7.9	19 (4) 25 (5)	0.3	5		●	●	●	●	●
10 / (6)	13	4	9.9	19 (4) 25 (5)	0.3	5		●	●	●	●	●
13 / (7)	16	6	12.9	19 (4) 25 (5)	0.4	5		●	●	●	●	●
16 / (8)	19	8	15.9	19 (4) 25 (5)	0.4	5		●	●	●	●	●
20 / (9)	23	10	19.9	19 (4) 25 (5)	0.4	5		●	●	●	●	●
25 / (10)	28	12	24.9	19 (4) 25 (5)	0.4	5		●	●	●	●	●
32 / (11)	35	16	31.9	25 (5) 30 (6)	0.4	5		●	●	●	●	●

订购示例:

2721.9E5.1550.A

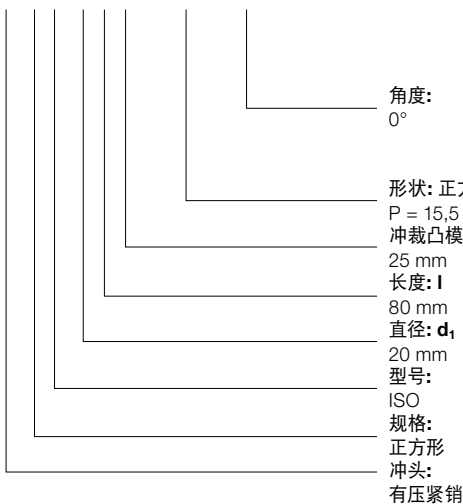

订货字母
= (A)

= 1550
 订购数字
= (5)
 订货字母
= (E)
 订购数字
= (9)
 订购数字
= (1)
 订购数字
= (2)

= 27

材料:

HSS

硬度:

杆部 $64 \pm 2 \text{ HRC}$

头部 $52 \pm 5 \text{ HRC}$

结构:

凸模头部热锻粗, 精磨支承面, 凸模柄部和切削刃形状。

防止凸模扭转平面与尺寸 $P = 0^\circ$ 的面保持标准要求的平行。

特别生产请咨询。

说明:

一起订购切削冲头和切削衬套时, 如果切削间隙 $\leq 0.04 \text{ mm}$, 则 FIBRO 会将形状的尖角倒圆。借此, 缩短安装时间并降低运行时边缘断裂的风险。