

# Pneumatic tools



**MADE IN GERMANY**

Process monitoring available

**Real classics**

Automation integration

Fast maintenance.

Comprehensive service.

Extensive range of special accessories available from stock

Original HONSEL spare parts

Individual adaptations are possible.

Decades of experience and continuous optimisation and further development make the successful HONSEL tools from the BZ and VNG Series your reliable partner in industrial series production as well as in workshops and trade applications.

A sturdy design and complete equipment with all the necessary conversion parts and special configurations such as axial versions or angular riveting heads leave nothing to be desired.



## ONLINE-CHECK-IN

Take advantage of the possibility of checking in repairs and maintenance in advance on our Internet website.

## The innovative system packaging

Compatible with all L-Boxxes from other manufacturers.

**L-BOXX®**



## HONSEL BZ 221A

In a special version for the production of a wide range of different cable drums.



## Comfortable

The air current holds the blind rivet securely in the nose piece in any position before setting – one hand remains free to position the part.



## Durable

High-quality, durable plastic housing.

## Flexible

Multiple compressed air connections to ensure the right working position for right-handed and left-handed users at all times.



## Individual

Individual setting possibilities for the extractor.

Nose pieces stored directly in the base of the tool.



## Safe and compact

Cover cap for reliable blind rivet setting without mandrel container in tight installation situations.



## Sturdy

Large, sturdy stud collector for sheared blind rivet studs.



## Practical

Integrated hanger bracket for working with balancer.

## Optimised

Very flat standard nose pieces with reduced cone angle length improve the setting behaviour and make the work process faster.



# Individual pneumatic tools



<b>Retrofits.</b>	<b>For use with standard rivets</b>	<b>Very small diameters</b> Ideal for confined riveting positions
-------------------	-------------------------------------	--



## Extended front sleeves

Extended front sleeves are ideally suited for reaching recessed riveting positions.

These are available from stock in lengths up to 210 mm and can be easily fitted to existing tools.

Blind rivets with extended mandrels are not necessary!

### Extended front sleeves BZ 103A (and BZ 102A)

321103010130	Conversion kit for extended front sleeve (130 mm)
321103010170	Conversion kit for extended front sleeve (170 mm)
321103010210	Conversion kit for extended front sleeve (210 mm)

### Extended front sleeves BZ 123A (and BZ 122A)

321123010130	Conversion kit for extended front sleeve (130 mm)
321123010170	Conversion kit for extended front sleeve (170 mm)
321123010210	Conversion kit for extended front sleeve (210 mm)

### Extended front sleeves VNG 703

321703010170	Conversion kit for extended front sleeve (170 mm)
--------------	---

### Extended front sleeves VNG 903

321903010170	Conversion kit for extended front sleeve (170 mm)
--------------	---



Example for an extended front sleeve with a special nose piece.

# Individual pneumatic tools



Extended front sleeve **with large holding area**

**Comfort trigger**

**AXIAL setting tool bracket** can be used horizontally and vertically without modification



## Axial setting

Riveting tools with a pistol grip have an optimum ergonomic design for horizontal rivet setting.

Correspondingly modified versions are available for rivet setting in vertical direction, especially in industrial series production applications. The tools are converted at the factory.

Our Technical Field Service is available for consultation on site.



320103000000-2-1	BZ 103A AXIAL
320123000000-2-1	BZ 123A AXIAL
320703000000-2-1	VNG 703 AXIAL
320903000000-2-1	VNG 903 AXIAL



# Individual pneumatic tools

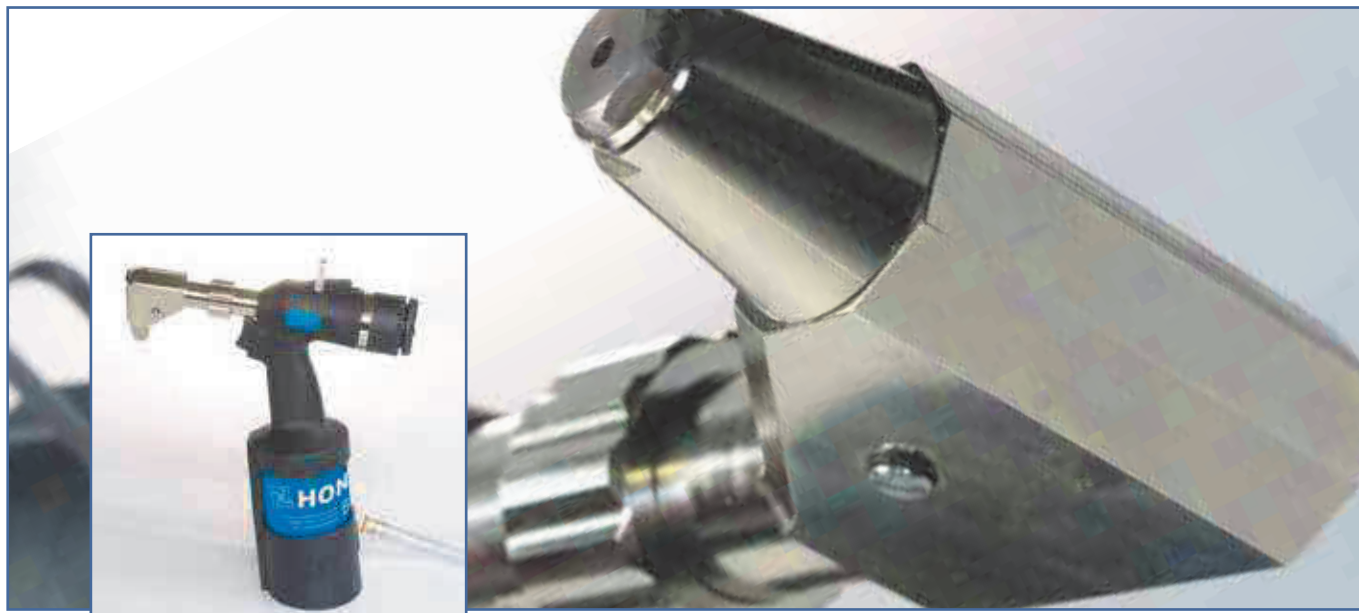

In sturdy  
high quality.

Any posi-  
tion can be  
reached.

Freely adjust-  
able.

## Angular riveting heads

Various **angular riveting heads** are available on request in order to be able to set blind rivets even at difficult-to-reach places.

### Angular riveting head 5000/12

Stroke	5,000 N
Overall height	85.6 mm
Width	24.0 mm
Length	117.0 mm

### Angular riveting head 9200/17

Stroke	9,200 N
Overall height	88.0 mm
Width	34.2 mm
Length	121.0 mm

321102000600	Angular rivet head 5000 12
360008800000	Angular rivet head 9200 17

# Individual pneumatic tools

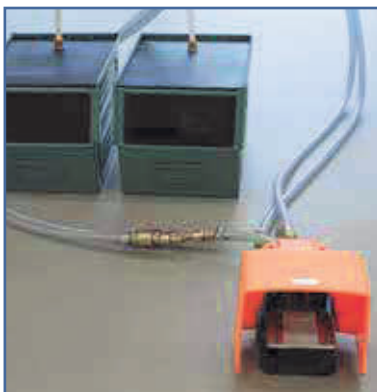
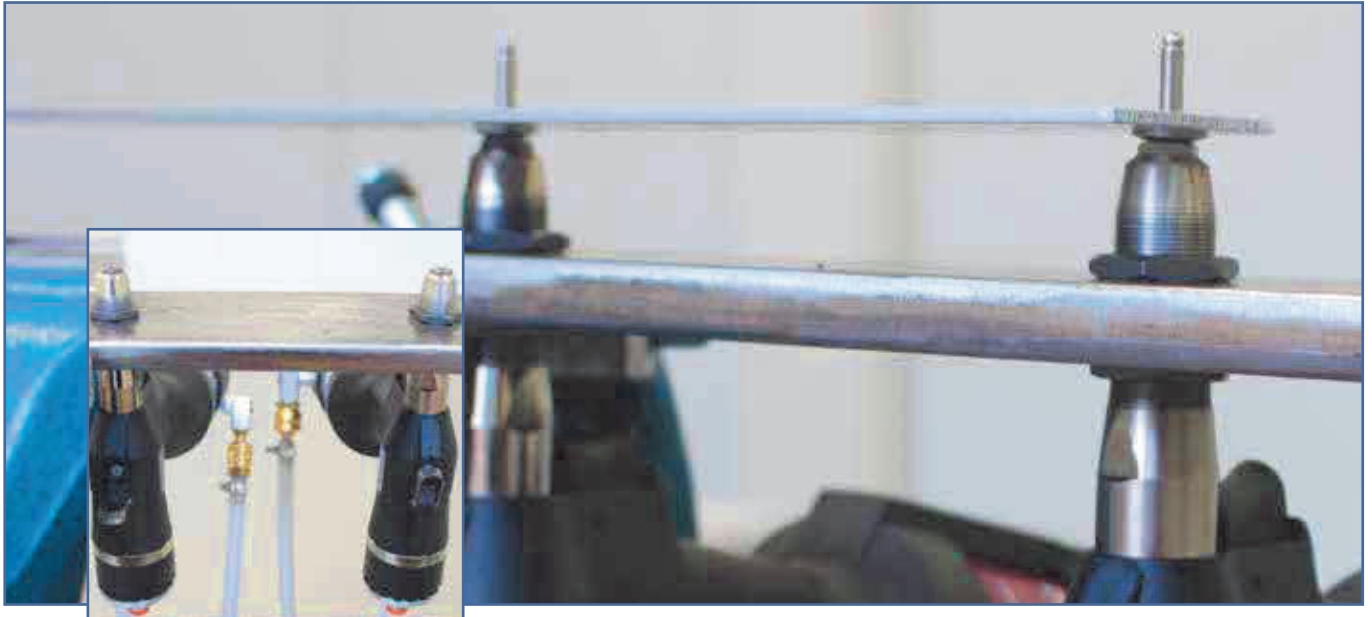

Perfect handling of the part

Simple and convenient

Greater **safety** and **cleanliness** at the workplace

## Stud discharge

The special screw fitting with plug connector can be used as an alternative to the normal stud collector. The sheared studs can be discharged through the hose (available in various lengths) into a large collecting bin. Frequent emptying is no longer necessary- you can continue to work without interruption. The workplace is kept free of sheared rivet studs.

## Foot release

Actuation of the riveting tool by foot release leaves both hands free for positioning the part to be riveted.

Ideal in combination with installation in an existing fixture / worktop. It is also possible to trigger several tools simultaneously with one foot release.

**We will be happy to provide you with further details.**

321101000016	Front sleeve for table mounting
321103500014	Lock nut for table mounting
321102000018	Mandrel discharge complet

320103000000	BZ 103 A prepared for foot controlled trigger
320123000000	BZ 123 A prepared for foot controlled trigger
320703000000	VNG 703 prepared for foot controlled trigger
321103001504	Foot controlled trigger complete

Not retrofittable!

# BZ 103A

Setting tool for blind rivets

Pneumatic-hydraulic | with permanent and intermittent extraction



## Reliable, sturdy, proven ten thousand times over.

The **HONSEL BZ 103A** has been one of the most popular standard tools for reliable blind riveting up to 5 mm rivet diameter for years. We will be happy to advise you on custom solutions tailored to your specific application.

<b>Weight</b> 1,800 g	<b>11,700 N</b> Setting force	<b>18 mm</b> Stroke	up to <b>5.0 mm</b> Diameter
Including all conversion parts	Individually and precisely adjustable stud extraction	<b>Very fast setting process</b>	Low air consumption. Reduced noise.

### Working range

	2,4	3,0	3,2	4,0	4,8	5,0	6,0	6,4	8,0
Aluminium									
Steel									
Stainless steel									
Copper alloys									



3:8 mm



< 75 dB(A) (68:32)



G 1/4 inside thread, can be fitted on left or right



5-7 bar



2:4 liter



### Scope of supply

- 1x BZ 103A pneumatic-hydraulic riveter in L-Boxx®
- 4x nose piece
- 1 set of clamping jaws
- 1 bottle of hydraulic oil with refill unit
- 2x stud collector

32010300000-90-1

Setting tool for blind rivets BZ 103 A



Further family facts on pneumatic tools can be found on page 73.

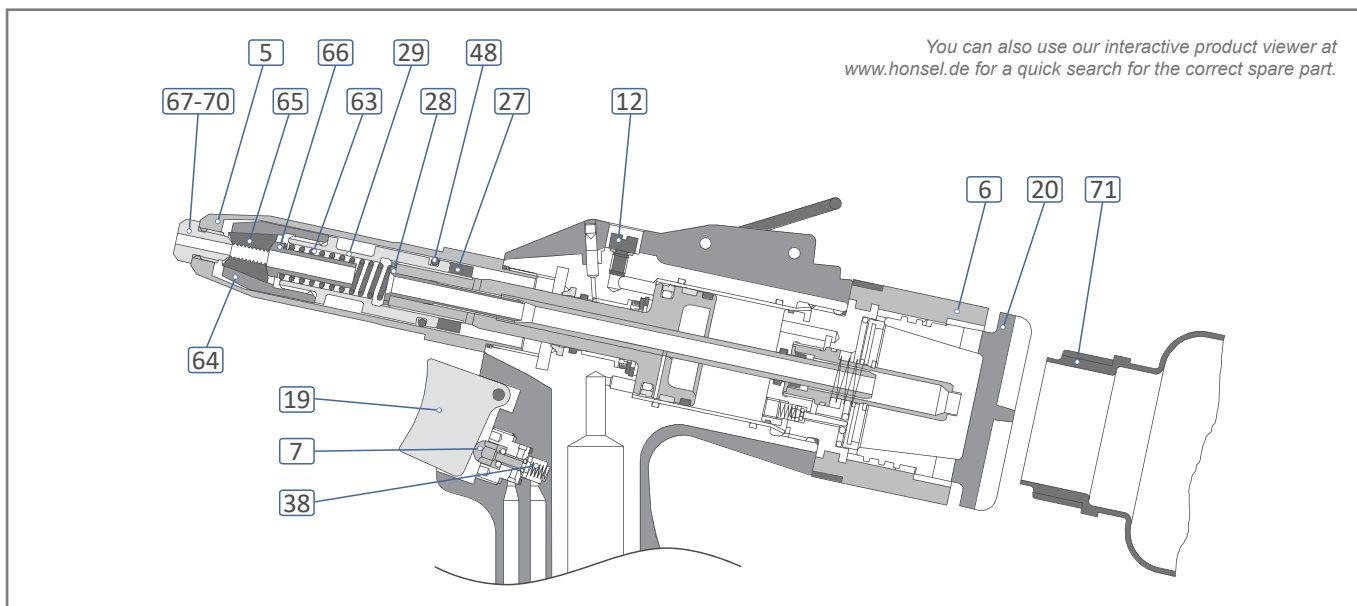

You can also use our interactive product viewer at [www.honsel.de](http://www.honsel.de) for a quick search for the correct spare part.

### Spare / wear parts and accessories

5	321101000016	Front sleeve
6	321102000006	Mandrel capture comple
7	321102000007	Release valve
12	321101000027	Oil drain plug including o-ring
19	321102000016	Trigger
20	321102000017	Closing cap mandrel capture
27	321102000023	Lock nut M12x1
28	321121000121	Vacuum nozzle
29	321102000025	Spacer

38	321102000036	Pressure spring trigger
48	321101000042	O-ring 15.0x2.0
63	311045000013	Pressure spring clamping mechanism
64	311045000010	Clamping sleeve
65	321070000241	Clamping jaws (1 set = 3 pcs)
66	311055000020	Guide sleeve
71	321082000010	Drilled mandrel collector
no fig.	321221000065	Extended mandrel collector
no fig.	321101000091	Wind deflector to divert the mandrel suction air flow BZ tools

### Standard nose pieces

67	321070000240	Standard nose piece 2.4 mm
68	321085000123	Standard nose piece 3.0/3.2 mm
69	321085000124	Standard nose piece 4.0 mm
70	321085000125	Standard nose piece 4.8/5.0 mm

**i** Special nose pieces for specific customer applications can be produced at short notice.

**▶** Extended front sleeves and further accessories on pages 74 - 77.

**▶** Pneumatic accessories on page 89.

### Special nose pieces

#### For recessed riveting points

##### Extended nose pieces 7 mm



321103932070	Extended nose piece 3.0/3.2 mm
321103940075	Extended nose piece 4.0 mm
321103950070	Extended nose piece 4.8/5.0 mm

##### Extended nose pieces 20 mm



321103932200	Extended nose piece 3.0/3.2 mm
321103940200	Extended nose piece 4.0 mm
321103950200	Extended nose piece 4.8/5.0 mm

Suitable for OPT® multigrip blind rivet with extended mandrel.

#### For 5.0 mm large dome head blind rivets



321085000511	Facade nose piece head 11.0 mm
321085000514	Facade nose piece head 14.0 mm
321085000516	Facade nose piece head 16.0 mm

#### For 4.8 mm FEROTM BOLT high-strength blind rivets



321101008401	Nose piece FEROTM-BOLT® 4.8 mm
--------------	--------------------------------

#### For 5.2 mm folding blind rivets



321103716052	Nose piece for folding blind rivets 5.2 mm
--------------	--

#### For burr-free setting of closed blind rivets



321085009124	CERTO®-Nose piece 4.0 mm
321085009125	CERTO®-Nose piece 4.8/5.0 mm



# BZ 123A

Setting tool for blind rivets

Pneumatic-hydraulic | with permanent and intermittent extraction



## Very powerful. Very large stroke.

The really powerful tool from HONSEL for blind rivets up to 8.0 mm diameter! With a very long stroke of 25 mm it is also eminently suitable for the setting of high-strength FERRO® BOLT blind rivets.

The BZ 123A is to be found in industrial series production, for example, of truck semi-trailers, and in individual vehicle and trailer construction – wherever large numbers of safety-relevant blind rivets have to be set quickly and reliably.

Weight <b>2,340 g</b>	<b>18,700 N</b> Setting force	<b>25 mm</b> Stroke	up to <b>8.0 mm</b> Diameter
Suitable for FERRO® BOLT	Individually and precisely adjustable stud extraction	<b>Very large stroke</b>	Low air consumption. Reduced noise.

## Working range

2,4	3,0	3,2	4,0	4,8	5,0	6,0	6,4	8,0
			Aluminium					
			Steel					
			Stainless steel					
			Copper alloys					



4,8 mm



< 75 dB(A) (68,32)



G 1/4 inside thread, can be fitted on left or right



5-7 bar



3,5 Liter



## Scope of supply

- 1x BZ 123A pneumatic-hydraulic riveter in L-Boxx®
- 4x nose piece
- 1 bottle of hydraulic oil with refill unit
- 1 set of clamping jaws
- 2x stud collector

320123000000-90-1

Setting tool for blind rivets BZ 123A

Further family facts on pneumatic tools can be found on page 73.

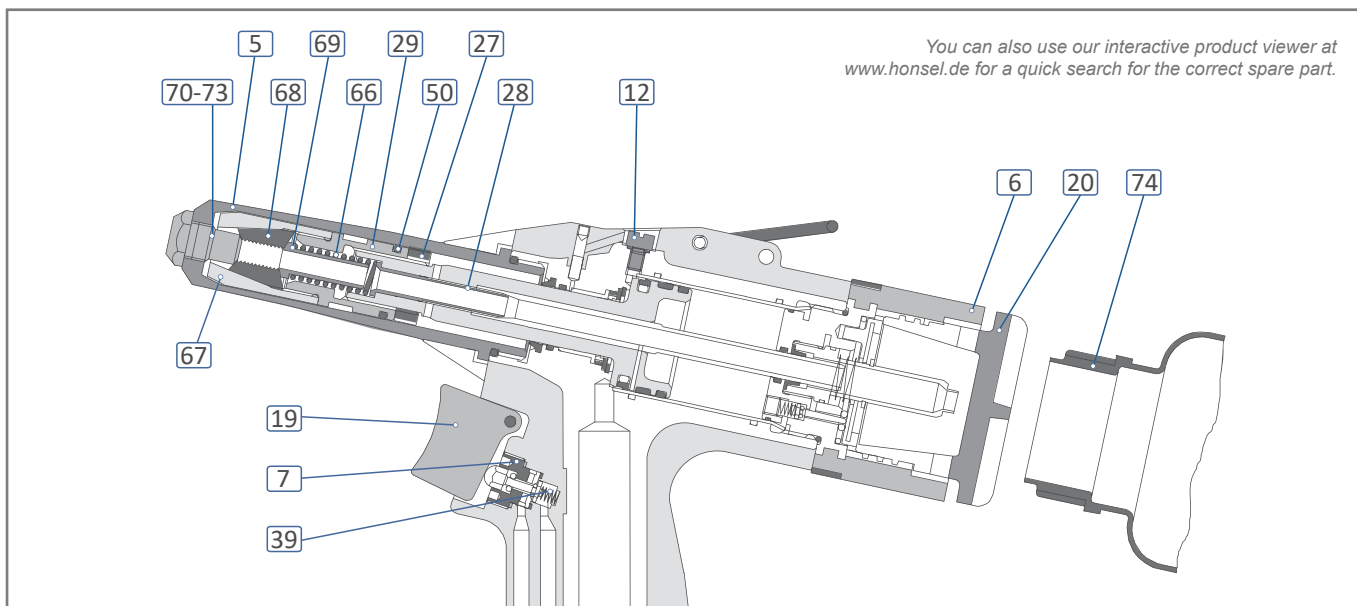

You can also use our interactive product viewer at [www.honsel.de](http://www.honsel.de) for a quick search for the correct spare part.

### Spare / wear parts and accessories

5	321121000016	Front sleeve incl. o-ring
6	321102000006	Mandrel capture comple
7	321102000007	Release valve
12	321101000027	Oil drain plug including o-ring
19	321102000016	Trigger
20	321102000017	Closing cap mandrel capture
27	321122000023	Lock nut M14 x 1.5
28	321221000014	Vacuum nozzle
29	321122000025	Spacer

39	321102000036	Pressure spring trigger
50	321120000014	O-ring 16.0x2.0
66	311045000013	Pressure spring clamping mechanism
67	321120000012	Clamping sleeve
68	321120000011	Clamping jaws (1 set = 3 pcs)
69	321120000010	Guide sleeve
74	321082000010	Drilled mandrel collector
o. Abb.	321221000065	Extended mandrel collector

### Standard nose pieces

70	321120000124	Standard nose piece 4.0 mm
71	321120000125	Standard nose piece 4.8/5.0 mm
72	321120000126	Standard nose piece 6.0 mm
73	321120000127	Standard nose piece 6.4/8.0 mm

- Special nose pieces for specific customer applications can be produced at short notice.
- Extended front sleeves and further accessories on pages 74 - 77.
- Pneumatic accessories on page 89.

### Special nose pieces

#### For recessed riveting points

##### Extended nose pieces 7 mm



321123940070	Extended nose piece 4.0 mm
321123950070	Extended nose piece 4.8/5.0 mm
321123960070	Extended nose piece 6.0 mm
321123964070	Extended nose piece 6.4 mm

##### Extended nose pieces 20 mm



321123940200	Extended nose piece 4.0 mm
321123950200	Extended nose piece 4.8/5.0 mm
321123960200	Extended nose piece 6.0 mm
321123964200	Extended nose piece 6.4 mm

Suitable for OPTO® multigrip blind rivet with extended mandrel.

#### For 5.0 mm large dome head blind rivets



321120000511	Facade nose piece head 11.0 mm
321120000514	Facade nose piece head 14.0 mm
321120000516	Facade nose piece head 16.0 mm

#### For 4.8 mm FEROTM BOLT high-strength blind rivets



361121008401	Nose piece FEROTM-BOLT® 4.8 mm
361121008601	Nose piece FEROTM-BOLT® 6.4 mm

#### For 5.2/6.3 mm folding blind rivets



321123716052	Nose piece for folding blind rivets 5.2 mm
321123716063	Nose piece for folding blind rivets 6.3 mm

# BZ 133A

Setting tool for blind rivets

Pneumatic-hydraulic | with permanent and intermittent extraction



## The specialist for blind rivets up to 8.0 mm.

Special high-strength FERRO® BULB blind rivets (and similar types) are set easily and reliably by the combination of short stroke and very high setting force.

Weight <b>2,340 g</b>	<b>24,000 N</b> Setting force	<b>18 mm</b> Stroke	up to <b>8.0 mm</b> Diameter
--------------------------	----------------------------------	------------------------	------------------------------------

### Working range

2,4	3,0	3,2	4,0	4,8	5,0	6,0	6,4	8,0
				Aluminium				
				Steel				
				Stainless steel				
				Copper alloys				



4,8 mm



< 75 dB(A)



G 1/4 inside thread, can be fitted on left or right



5-7 bar



3,5 Liter

### Scope of supply

- 1x BZ 133A pneumatic-hydraulic riveter in L-Boxx®
- 4x nose piece
- 1 set of clamping jaws
- 1 bottle of hydraulic oil with refill unit
- 2x stud collector

320133000000-1-1

Setting tool for blind rivets BZ 133A

Further family facts on pneumatic tools can be found on page 73.

## Spare and wear parts

321121000016	Front sleeve incl. o-ring
321102000007	Release valve
361122000022	Clamping sleeve
361122000020	Clamping jaws (1 set = 3 pcs)
321120000010	Guide sleeve
321221000014	Vacuum nozzle
321102000016	Trigger
311045000013	Pressure spring clamping mechanism
321101000027	Oil drain plug including o-ring
321102000017	Closing cap mandrel capture
321082000010	Drilled mandrel collector
321221000065	Extended mandrel collector

## Nose pieces

321120000124	Standard nose piece 4.0 mm
321120000125	Standard nose piece 4.8/5.0 mm
321120000126	Standard nose piece 6.0 mm
321120000127	Standard nose piece 6.4/8.0 mm



## Reliable with low wear.

On the HONSEL BZ 143A, the clamping jaws are specially adapted to the trapezoidal grooves of the rivet mandrel.

Together with the modified clamping mechanism, this ensures safe and **positive-fit setting** of high-strength blind rivets of type FERRO® BULB (or comparable types) with a stud diameter of 3.8 to 6.15 / 6.5 mm is guaranteed!

<b>Weight</b> <b>2,500 g</b>	<b>24,000 N</b> Setting force	<b>18 mm</b> Stroke	<b>8.0 mm</b> Diameter
Suitable for FERRO® BULB	Optimised for grooved mandrels	Positive-fit setting	Minimum wear on the clamping jaws

## Working range

2,4	3,0	3,2	4,0	4,8	5,0	6,0	6,4	8,0
							Aluminium	
							Steel	
							Stainless steel	



6,5 mm



&lt; 75 dB(A)



G 1/4 inside thread, can be fitted on left or right



5-7 bar



3,5 Liter

## Scope of supply

- 1x BZ 143A pneumatic-hydraulic riveter in L-Boxx®
- 2x nose piece
- 1 bottle of hydraulic oil with refill unit
- 1 set of clamping jaws
- 2x stud collector

320143000000-1-1

Setting tool for blind rivets BZ 143A

Further family facts on pneumatic tools can be found on page 73.

## Spare and wear parts

321528045080	Clamping jaws (1 set = 3 pcs)
321143000010	Guide sleeve
321143000012	Clamping sleeve
321143000013	Pressure spring
321143000016	Front sleeve
321143000025	Spacer
321082000010	Drilled mandrel collector
321221000065	Extended mandrel collector
321101000027	Oil drain plug including O-ring



## Nose pieces

321528200066	Retention nose piece 6.4 mm
321528200067	Retention nose piece 7.8 mm



# VNG 703

Setting tool for blind rivet nuts and studs  
Pneumatic-hydraulic | kraftgesteuert



## The force-controlled tool for fast handling of large numbers in series production.

The setting and control of the required setting force guarantees that the blind rivet nut is always optimally and gently set. The VNG 703 also features a user-friendly design and easy handling.

Switching from forward to return travel is extremely quick. Slight pressure on the mandrel automatically threads on the blind rivet nut and unthreads it again fully automatically after setting.

Weight <b>2,500 g</b>	<b>20,000 N</b> Setting force	<b>9 mm</b> Stroke	up to <b>M8</b>
Stepless setting of the setting force	Fast processing of <b>large</b> quantities	<b>Simple handling</b>	Automatic threading on and off



Typically HONSEL. Simple and practical:  
**Stepless setting** of the setting force individually for each fastener.



Special accessories: **Angular adapter** to maintain the necessary perpendicularity to the part.



### Working range

M3	M4	M5	M6	M8	M10	M12
	Aluminium					
Steel						
Stainless steel						



	Steel			
--	-------	--	--	--



5-7 bar



< 75 dB(A) (68,32)



G 1/4 inside thread, can be fitted on left or right



4,4 Liter



Aufschrauben 1800 U/min.  
Ausschrauben 2500 U/min.

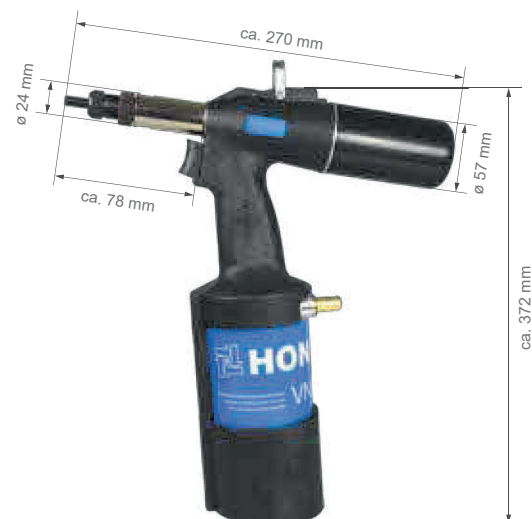

### Scope of supply

- 1x VNG 703 pneumatic-hydraulic riveter in L-Boxx®
- 5x conversion kits for blind rivet nuts
- 1 bottle of hydraulic oil with refill unit

320703000000-90-1

Setting tool for blind rivet nuts VNG 703

Further family facts on pneumatic tools can be found on page 73.

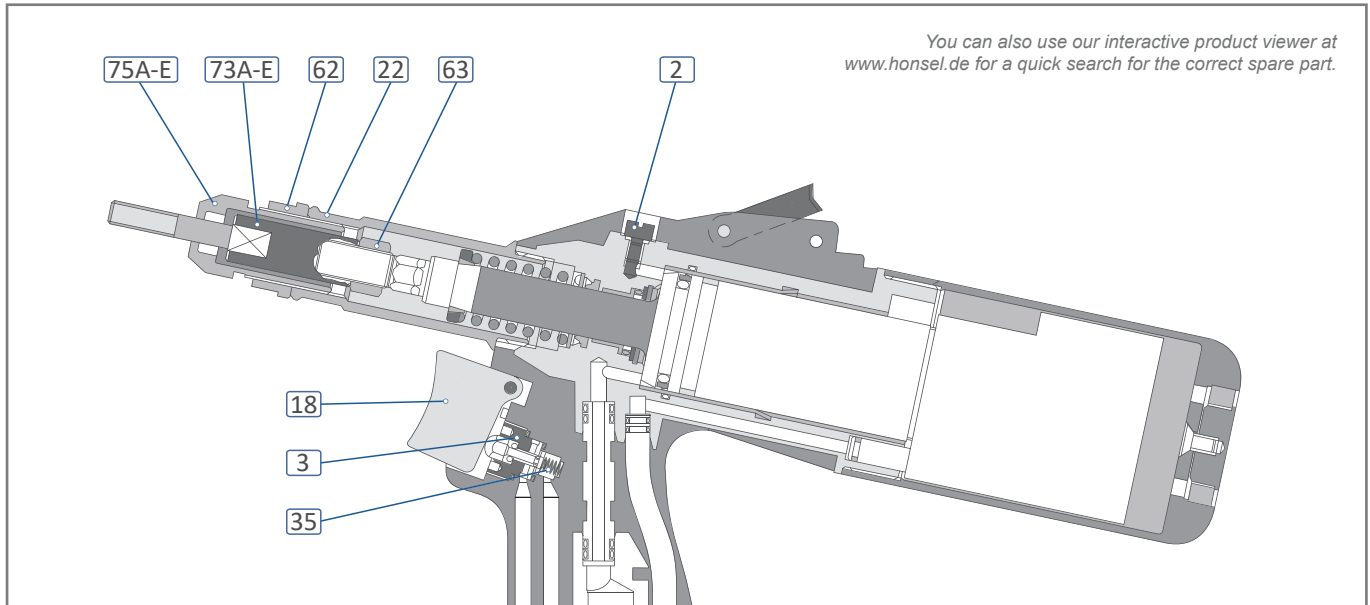

You can also use our interactive product viewer at [www.honsel.de](http://www.honsel.de) for a quick search for the correct spare part.

### Spare and wear parts

2	321101000027	Oil drain plug M4 including o-ring
3	321102000007	Release valve
18	321102000016	Trigger
22	321703000024	Front sleeve
35	321102000036	Pressure spring trigger
62	321801000074	Lock nut M18x1
63	361802191075	Lock nut M9x0.75

### Nose pieces

75A	31180000203	Nose piece M3
75B	31180000204	Nose piece M4
75C	31180000205	Nose piece M5
75D	31180000206	Nose piece M6
75E	31180000208	Nose piece M8

### Nose pieces HEADLESS



321800004206	Nose piece M6 HEADLESS
321800004208	Nose piece M8 HEADLESS

### Mandrels/sleeves

73A	321800008030	Mandrel M3
73B	321800008040	Mandrel M4
73C	321800008050	Mandrel M5
73D	321800008060	Mandrel M6
73E	321800008080	Mandrel M8
	321800009040	Threaded sleeve M4 RIFBOLT
	321800009050	Threaded sleeve M5 RIFBOLT
	321800009060	Threaded sleeve M6 RIFBOLT

### UNC/UNF Mandrels



321800975006	Mandrel UNC 6-32
321800975008	Mandrel UNC 8-32
321800975010	Mandrel UNC 10-24
321800975014	Mandrel UNC 1/4-20
321800975516	Mandrel UNC 5/16-18
321800975100	Mandrel UNF 10-32
321800975140	Mandrel UNF 1/4-28
321800122517	Mandrel UNF 5/16-24

### Nose pieces UNC/UNF Mandrels

31180000204	Nose piece M4 for mandrel UNC 6-32
31180000205	Nose piece M5 for mMandrel UNC 8-32 and 10-24, UNF 10-32
31180000208	Nose piece M8 for mandrel UNC 1/4-20 and 5/16-18, UNF 1/4-28 and 5/16-24

! Special accessories, nose pieces and mandrels, for example in extended form or for inside riveting locations available on request.

▶ Pneumatic accessories on page 89.



# VNG 903

Setting tool for blind rivet nuts and studs  
Pneumatic-hydraulic | stroke-controlled



## The stroke-controlled solution for large tasks

The sophisticated design and individual setting options make the HONSEL VNG 903 your perfect tool for the easy and reliable setting of all common blind rivet nuts.

These are automatically threaded onto the mandrel with light pressure. Threading is likewise stopped automatically; the threading time can be set.

Also easily handled:  
self-clinching elements.



Weight <b>2,700 g</b>	<b>29,000 N</b> Setting force (at 7 bar)	<b>9 mm</b> Stroke	up to <b>M12</b> (optional)
Sophisticated design	Individual setting options	<b>Comfortable</b> <b>Simple</b> <b>Practical</b>	Automatic threading on and off

## Working range

M3	M4	M5	M6	M8	M10	M12
	Aluminium					optional
	Steel					optional
	Stainless steel					optional



Steel		
-------	--	--



5-7 bar



< 75 dB(A) (68,32)



G 1/4 inside thread, can be fitted on left or right



7.5 Liter



Screwing in 1800 rpm  
Unscrewing 2500 rpm



Exact adjustment of the setting stroke via scale on the adjustment cap.



## Scope of supply

- 1x VNG 903 pneumatic-hydraulic riveter in L-Boxx®
- 5x conversion kits for blind rivet nuts
- 1 bottle of hydraulic oil with refill unit

320903000000-90-1

Setting tool for blind rivet nuts VNG 903

Further family facts on pneumatic tools can be found on page 73.



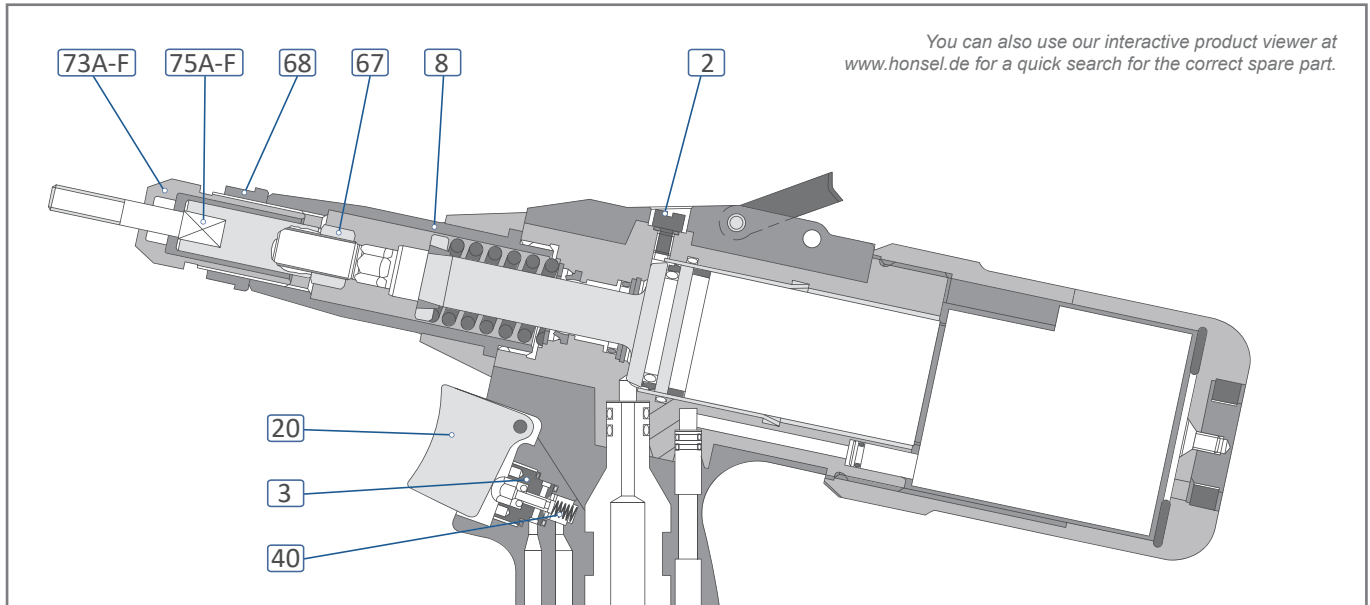

You can also use our interactive product viewer at [www.honsel.de](http://www.honsel.de) for a quick search for the correct spare part.

## Spare and wear parts

2	321101000027	Oil drain plug including O-ring
3	321102000007	Release valve
20	321102000016	Trigger
8	321903000016	Front sleeve
40	321102000036	Pressure spring trigger
67	361802191075	Lock nut M9x0.75
68	321801000074	Lock nut M18x1

## Nose pieces

73A	31180000204	Nose piece M4
73B	31180000205	Nose piece M5
73C	31180000206	Nose piece M6
73D	31180000208	Nose piece M8
73E	31180000210	Nose piece M10
73F	31180000212	Nose piece M12

## Nose pieces HEADLESS



321800004206	Nose piece M6 HEADLESS
321800004208	Nose piece M8 HEADLESS
321800004210	Nose piece M10 HEADLESS



The **stroke circlip** prevents an unwanted shifting of the adjusting cap.

321801000080	Stroke circlip
--------------	----------------

## Mandrels/sleeves

75A	321800008040	Mandrel M4
75B	321800008050	Mandrel M5
75C	321800008060	Mandrel M6
75D	321800008080	Mandrel M8
75E	321800008100	Mandrel M10
75F	321800008120	Mandrel M12
74A	321800009040	Threaded sleeve M4 RIFBOLT
74B	321800009050	Threaded sleeve M5 RIFBOLT
74C	321800009060	Threaded sleeve M6 RIFBOLT
74D	321800009080	Threaded sleeve M8 RIFBOLT

## UNC/UNF Mandrels



321800975008	Mandrel UNC 8-32
321800975010	Mandrel UNC 10-24
321800975014	Mandrel UNC 1/4-20
321800975038	Mandrel UNC 3/8-16
321800975516	Mandrel UNC 5/16-18
321800975100	Mandrel UNF 10-32
321800975140	Mandrel UNF 1/4-28
321800122380	Mandrel UNF 3/8-24
321800122517	Mandrel UNF 5/16-24
321800122716	Mandrel UNF 7/16-20

## Nose pieces UNC/UNF Mandrels

31180000205	Nose piece M5 for mandrel UNC 8-32 and 10-24, UNF 10-32
31180000208	Nose piece M8 for mandrel UNC 1/4-20 and 5/16-18, UNF 1/4-28 and 5/16-24
31180000210	Nose piece M10 for mandrel UNC 3/8-16
31180000212	Nose piece M12 for mandrel UNF 7/16-20



# VNG 753

Setting tool for folding blind rivet nuts  
Pneumatic-hydraulic | stroke-controlled



Folding blind rivet nuts are used wherever fragile components are connected and the forces that occur must be distributed material-friendly over the large folded setting head. Due to the very large stroke of up to 15 mm and with extended threaded mandrels these can be set quickly and easily.

Weight <b>2,900 g</b>	<b>19,000 N</b> Setting force	<b>8-15 mm</b> Stroke	up to <b>M10</b> (optional)
For folding blind nuts	Individual Setting options	<b>Very long stroke</b>	Automatic threading on and off



## Working range

M3	M4	M5	M6	M8	M10	M12
		optional	Steel		optional	

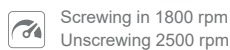
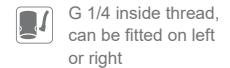
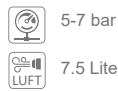

## Spare parts

321101000027	Oil drain plug including O-ring
321801000074	Lock nut M18x1
321801000080	Stroke circlip

## Nose pieces / mandrels

311800000205	Nose piece M5
311800000206	Nose piece M6
311800000208	Nose piece M8
311800000210	Nose piece M10
361800008513	Mandrel M5 extended by 5 mm
361800008613	Mandrel M6 extended by 6 mm
361800008813	Mandrel M8 extended by 10 mm
361800098101	Mandrel M10 extended by 5 mm



## Scope of supply

- 1x VNG 753 pneumatic-hydraulic riveter in L-Boxx®
- Conversion kits for M6 and M8 folding blind rivet nuts
- 1 bottle of hydraulic oil with refill unit

320753000000-1-1    Setting tool for blind rivet nuts VNG 753

Further family facts on pneumatic tools can be found on page 73.

# Pneumatic accessories for BZ and VNG tools

## Add to your order!

Have you considered the necessary pneumatic accessories? Save unnecessary work and order the appropriate accessories for the HONSEL pneumatic tools of the BZ and VNG series together with your tool order!



Pos.	Artikel-Nr.	Bezeichnung
1	321121000053-3-1	Angular pivoting fitting aluminium incl hose with 1/4" outside thread and hose coupling
2	321121000053-1-1	Pivoting threaded pipe angle. aluminium
3	321121000053-2-1	Pivoting threaded pipe angle. stainless steel
4	321121000021-1-1	Valve extension 1/8"
5	321121000057-1-1	Screw-in hose connector -set- G 1/4" 6 mm
6	321121000058-1-1	Screw-in hose connector -set- G 1/4" 9 mm
7	320848000009-1-1	Plug connection 7 mm G 3/8 for compressed-air service unit
8	320848000012-1-1	Plug connection 7 mm G 1/4 for pivoting threaded pipe angle
9	320848000010-1-1	Coupling G 1/4"
10	320848000004-1-1	Pressure controller 7 bar
11	320848000005-1-1	Compressed air spiral hose incl coupling and plug connection -length 4 m-
12	320848000006-1-1	Compressed air spiral hose incl coupling and plug connection -length 6 m-
13	320848000008-1-1	Compressed air spiral hose incl coupling and plug connection -length 8 m-
14	321101006467-1-1	Oil re-fill unit for all tools of BZ- and VNG-series
15	320848000001-1-1	Filter regulator G3/8 complete
16	320848000002-1-1	Maintenance unit. 2-part. complete
no fig.	320848000003-1-1	Replacement filter for filter regulator
no fig.	320848000011-1-1	1 litre of pneumatic motor oil
no fig.	321101000091-1-1	Wind deflector BZ tools

For smooth operation of our pneumatic tools, please be sure to observe the information in our operating manuals!

Important for maintaining a good performance and avoiding damage are the **characteristics of the compressed air used.**

- Condensation hinders the lubrication and causes corrosion inside the tool!
- The motors have to be continuously lubricated.



For BZ tools water trap / pressure reducer G3/8 filter regulator with filter pressure regulator, manometer, plastic protective cage, mounting bracket, G3/8 plug connection and quick-coupler.



For VNG tools water trap / pressure reducer / oil nebuliser 2-piece G3/8 air conditioner, including plastic protective cage, mounting bracket, G3/8 plug connection, quick-coupler and 1 litre of pneumatic motor oil.