



CADENAS + Misumi Building A Strong Relationship

Welcome To Augsburg
March 2007



MISUMI



CADENAS Technologies AG

Founded:

1992

Headquarter:

Augsburg/Germany

Logo:

CADENAS (span. Process Chains)



Subsidiaries:

CADENAS DE Augsburg, Munich, Wolfsburg, Stuttgart, Essen
PARTsolutions USA in OHIO, MICHIGAN, CALIFORNIA, NEW YORK
CADENAS ITA in Modena
CADENAS A in Wels
CADENAS F in Lyon
CADENAS KRO in Slavonski Brod
CADENAS KR in Seoul
CADENAS E in Barcelona
CADENAS CN in Shanghai
CADENAS JP in Tokyo (Assets of former WEB2CAD Japan til 2008)

Distributions in CH, S, DK, N, E, PT, NL
Coming soon in 2007 UK



Licenses/Experience:

~ 125,000 licenses sold, and app. 400 catalogs completed

Employees:

~ 230 Worldwide

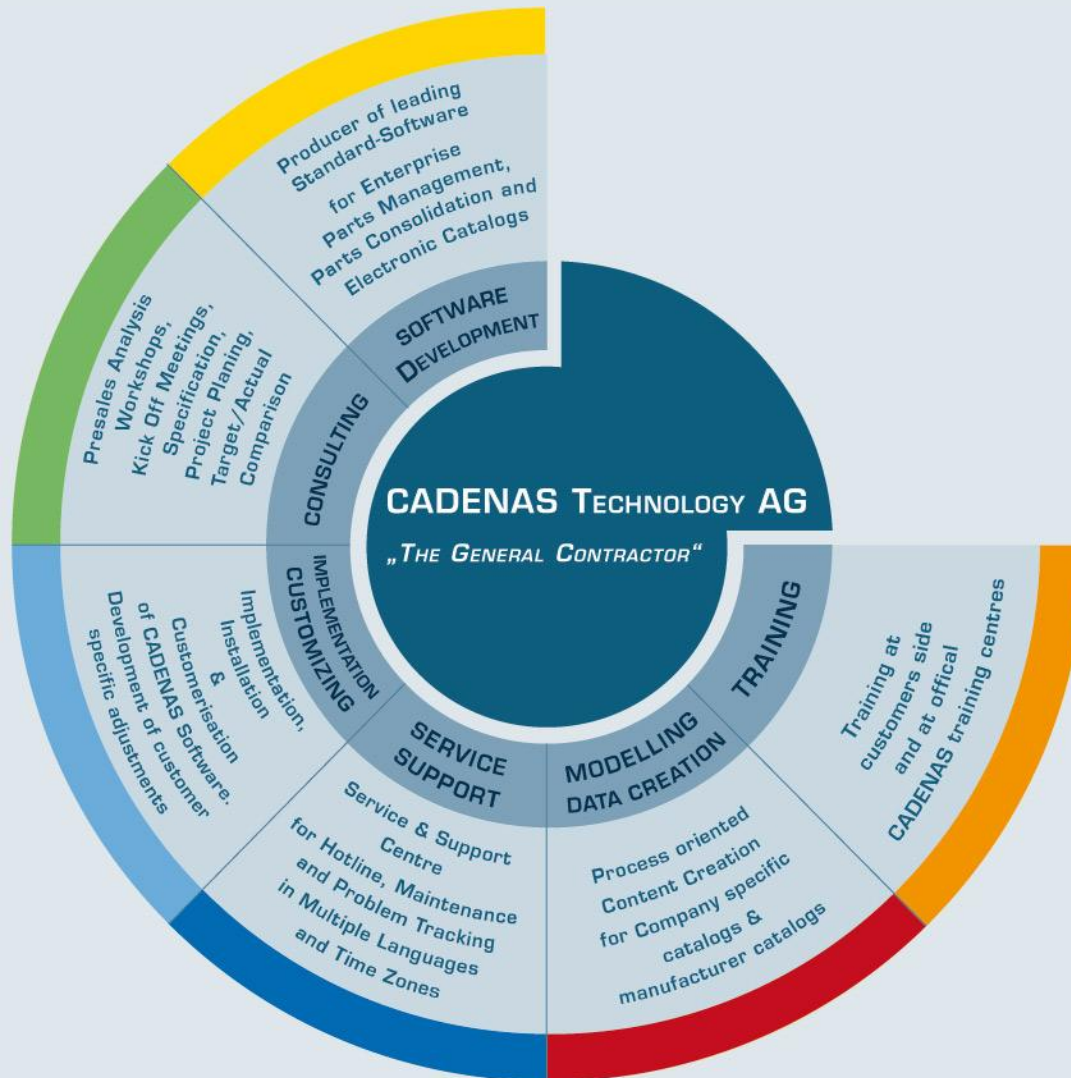

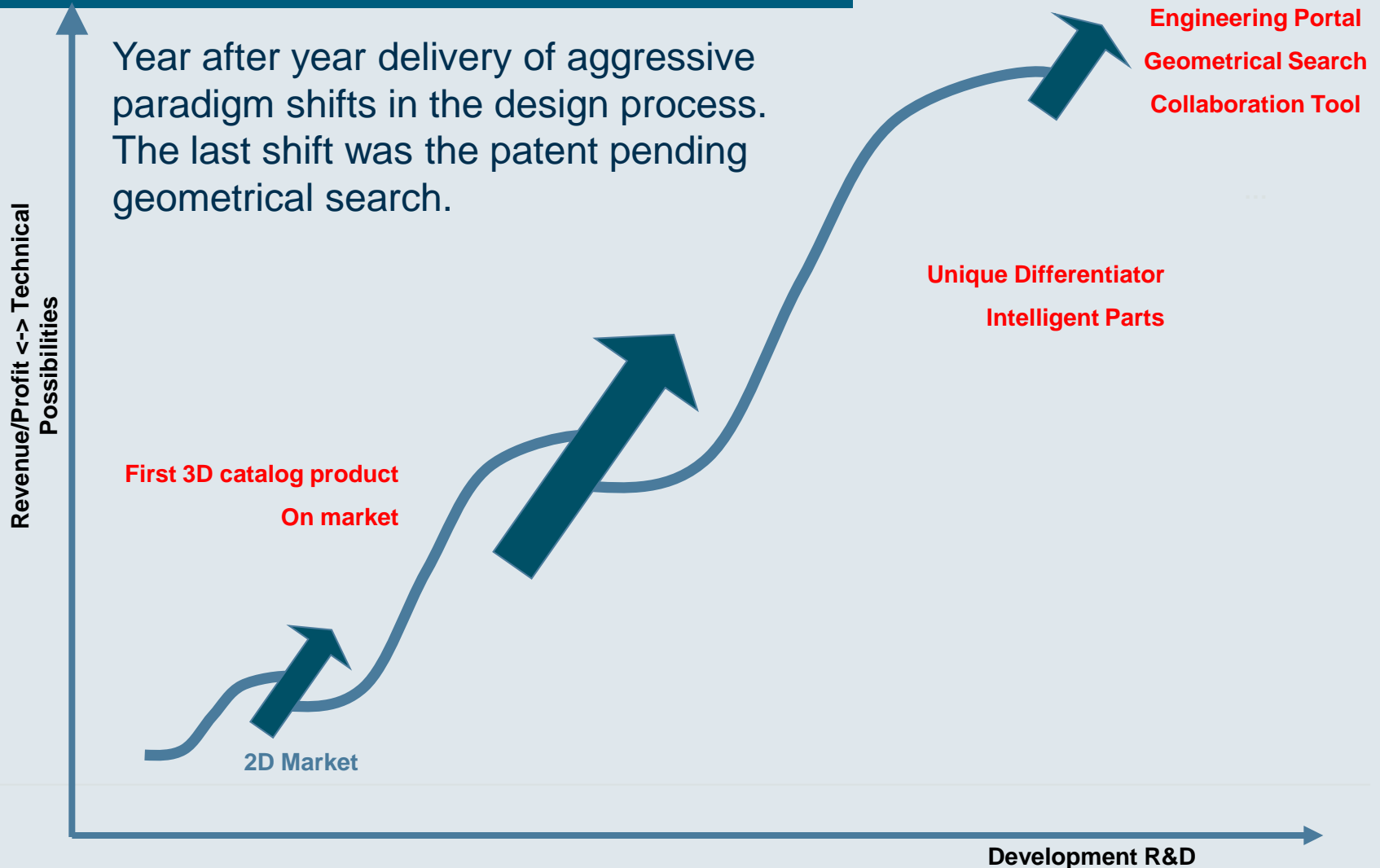

Marketing Power/ Market Position

Project Management & Single Source

Smart Parts & Processes

Printed Catalog

Assistant & Configurator

BMECAT & WebEDI

Paradigm Shifts

Geometrical Search

Collaboration





Worldwide Leadership Bringing To You app. 3.100.000 Prospect Customers

AMERICAS



US: Autodesk Content Center, PTC, Kubotek, other CAD OEM partnerships
Penton Media / Machine Design

EUROPE

DE: Most customers
AT/CH: Most customers
IT: Most customers
FR: Good Market Position
ES: Good Market Position
SK: Good market Position
RU: First exclusive contracts with CAD OEMS

APAC

CN: Exclusive contract with the Chinese SDO
KR: Most customers
JP: Most customers
Migration from WEB2CAD

-  Leadership (Most Customers)
-  Good Market Position (Many Customers)

EXTRACT

+ New leadership in APAC with WEB2CAD Asset take over

Many Prospect Customers Through Different Portals

CADENAS PARTserver

<http://www.partserver.de>

800.000 users

- Autodesk Content Center

Autocad, Mechanical DT, Inventor

<http://autodesk.partcommunity.com> **1.500.000** prospects

- Alibre CAD Portal -

<http://alibre.partcommunity.com>

106.000 prospects

- Pro/Engineer by PTC

PARTsolutions

<http://catalogs.ptc.com>

370.000 prospects

- Solidworks MyCADlibraries

(SolidAlliance)

<http://www.mycadlibraries.com>

25.000 prospects

- Penton Machine Design

Big Technical Publisher in USA

<http://www.machinedesign.com>

/cadlibrary

300.000 prospects





3.100.000 prospect customers
in over **100** countries



Direct Embedded In Autodesk Inventor Autodesk Content Center

The screenshot displays the Autodesk Inventor 11 interface with the 'Supplier Content Center' option highlighted in the 'Web' menu. The background shows the Autodesk Manufacturing Supplier Content Center website, which includes a login form, a 'For Designers' section with a list of benefits, and a 'For Suppliers' section with instructions on how to use the platform. Product categories like Numatics, Smalley Steel Ring, MISUMI, and D-M-E are also visible.

EXTRACT

+ Autodesk users select components direct from their CAD-environment

+ Autodesk has app. 6 Mio users

Access Autodesk Manufacturing Supplier Content Center

A Couple Of PENTONs Magazines

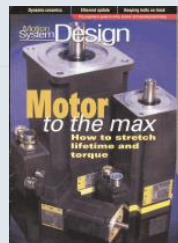
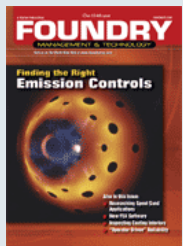
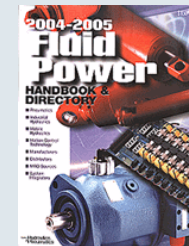
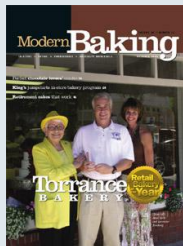

Results

Project start: 2001, creation of selected products

Objective: High end service for the engineering customers, not only for purchasing but also during the mechanical design period.

“Be early in the BOM creation!”

In 2004: 10x times more downloads per month with PARTsolutions technology as at the project beginning 2001.

Objective met 100% !



Top 10 preferred catalogs

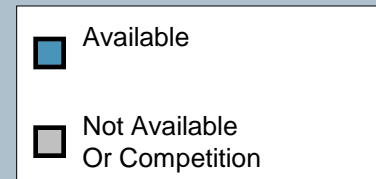
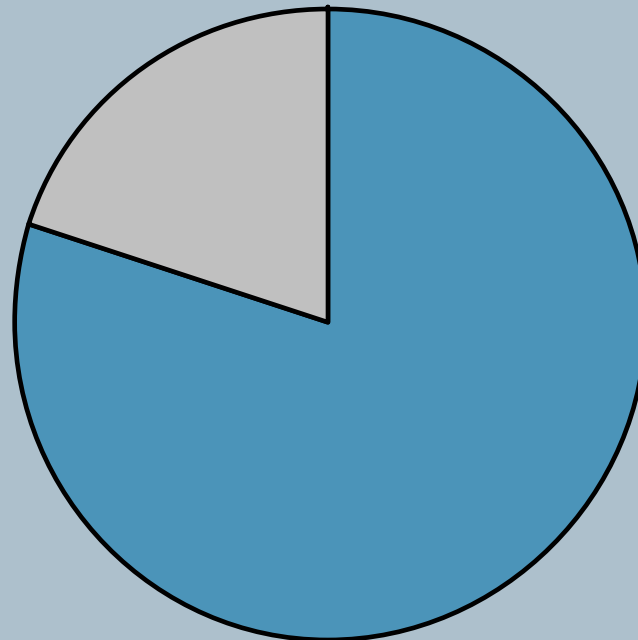

Top 25 preferred catalogs

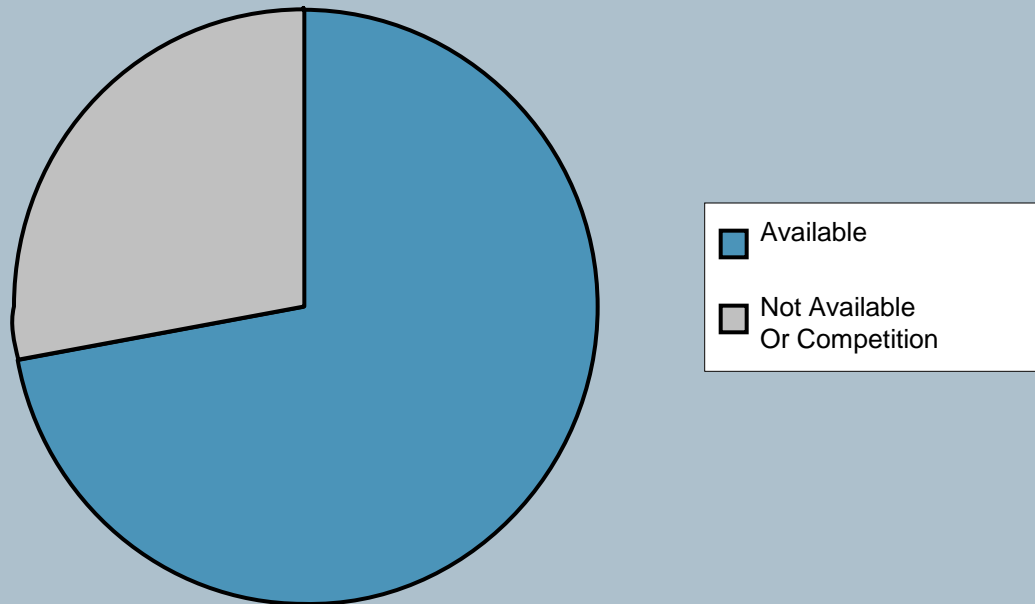

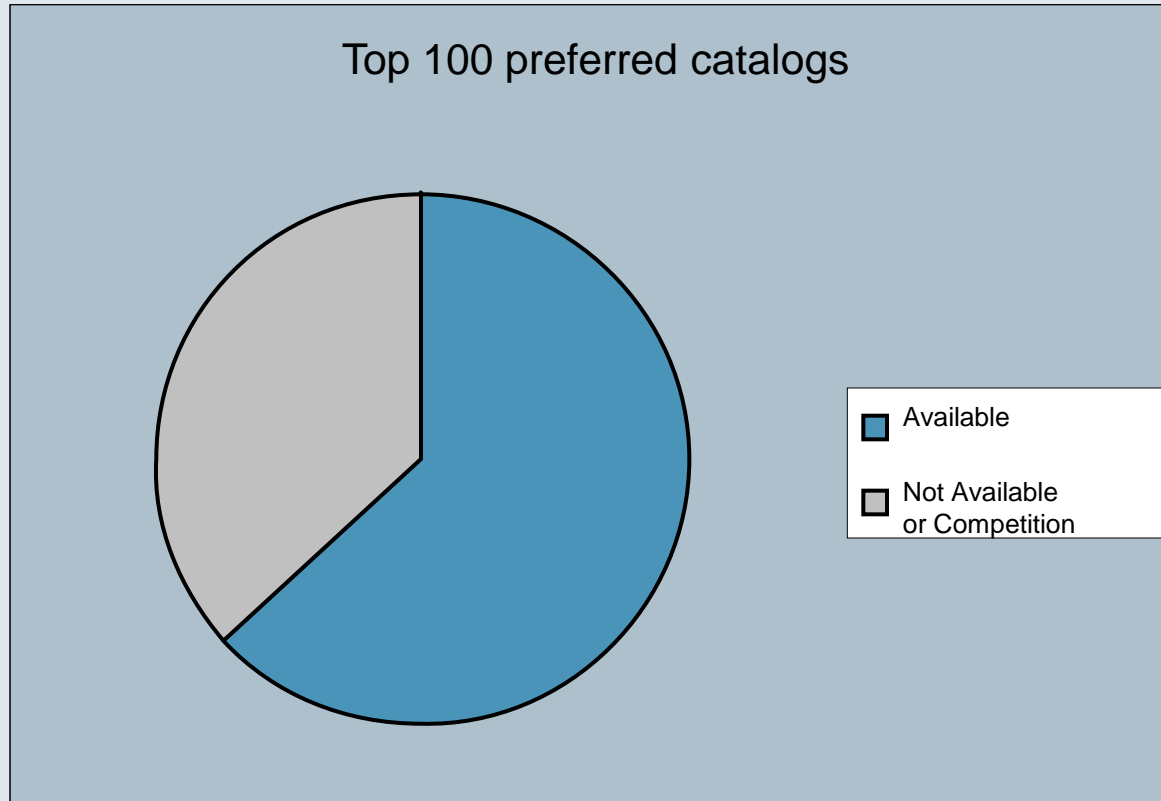

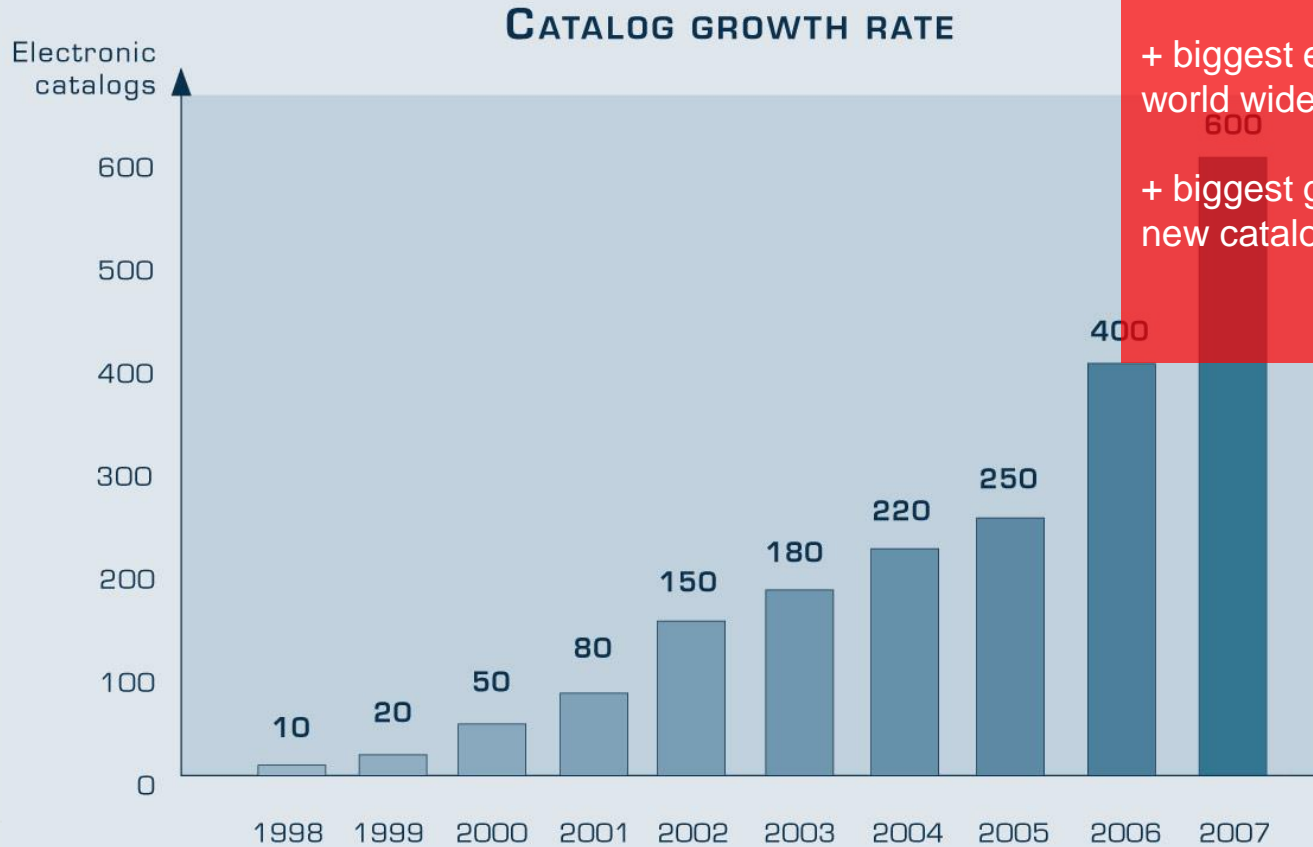

EXTRACT

- + biggest experience world wide
- + biggest growth in new catalogs in 2006

Marketing Power/ Market Position

Project Management & Single Source

Smart Parts & Processes

Printed Catalog

Assistant & Configurator



BMECAT & WebEDI

Paradigm Shifts

Geometrical Search

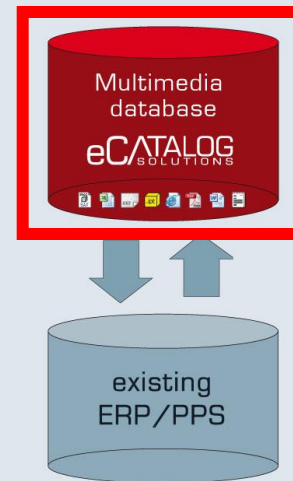
Collaboration



Output media:	
	▶ Web
	▶ CD-ROM
	▶ Print catalog
Improve your marketing:	
	▶ Product portals with over 2.8 million users
	▶ Supplier Parts Library PARTSolutions
	▶ Market places with BMEcat
	▶ e-Shop
Features:	
	▶ Product configurator
	▶ Customer Relationship Management
	▶ Document Management
	▶ Support Management
	▶ Market research



Central Multimedia Single SourceDB Administrates All Types Of Documents



Documentation Of Change Management

Datum	Autor	QA-Status	Bemerkung
03/14/2005	T.Denk		QA-Stufe angepasst
03/14/2005	T.Denk		QA-Stufe angepasst
03/23/2005	T.Denk	7>2	QA State set
03/23/2005	T.Denk	2	changes2server
04/14/2005	T.Tomic	2>3	in Bearbeitung
04/14/2005	T.Tomic	3>4	CONTROL
04/14/2005	T.Tomic	3>4	PART project: TestMeta Korrektur
04/14/2005	T.Tomic	5>6	Freigabe
04/14/2005	T.Tomic	6	fertig

Shows User Access Rights For Parts

Current State

Integration Of All
Project Members To
Project Progress

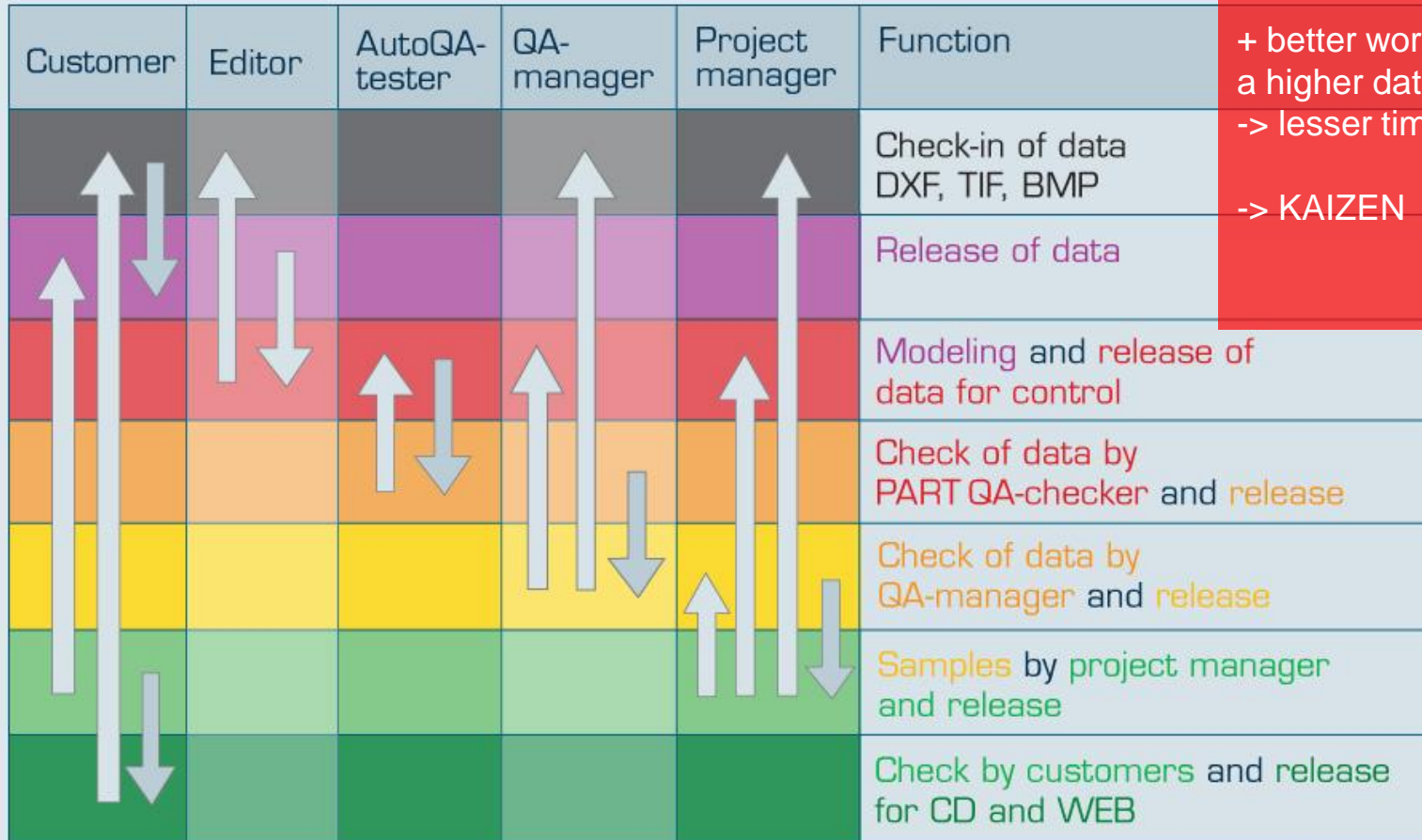

EXTRACT

+ better workflow is forcing
a higher data quality
-> lesser time for complaints
-> KAIZEN



Projekt: gehause_4a

Ischneeberger/monorail_bmlamsa_4a/gehause_4a.prj
580 003 858
AMSA 4A, Gehäuse

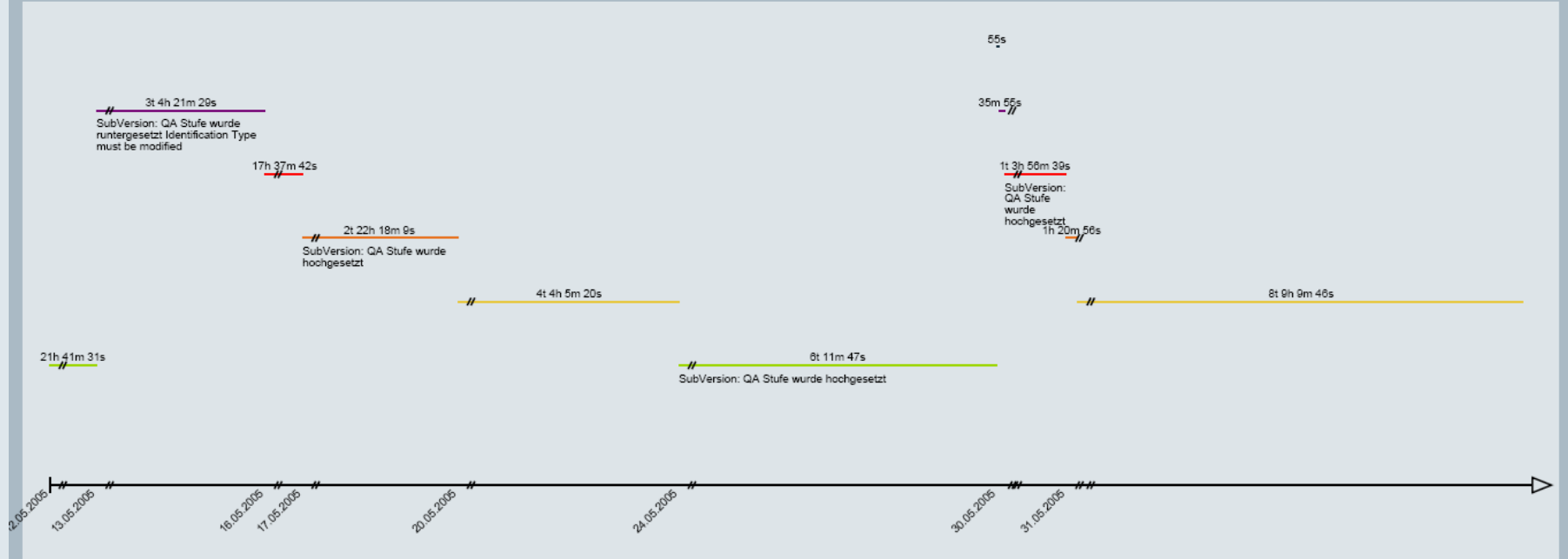

History:

Datum	Status	Autor	Beschreibung	Datum	Status	Autor	Beschreibung
12.05.2005 12:00:47	7	T.Denkel	SubVersion: QA Stufe wurde hochgesetzt check ok	24.05.2005 10:04:58	7	T.Denkel	SubVersion: QA Stufe wurde hochgesetzt
13.05.2005 09:42:18	2	T.Denkel	SubVersion: QA Stufe wurde runtergesetzt Identification Type must be modified	30.05.2005 10:16:45	1	T.Denkel	SubVersion: QA Stufe wurde runtergesetzt corrections from customer to cro
16.05.2005 14:03:47	3	B.Kovacevic	SubVersion: QA Stufe wurde hochgesetzt	30.05.2005 10:17:40	2	T.Denkel	SubVersion: QA Stufe wurde hochgesetzt start with corrections
17.05.2005 07:41:29	4	B.Kovacevic	SubVersion: QA Stufe wurde hochgesetzt	30.05.2005 10:53:35	3	B.Kovacevic	SubVersion: QA Stufe wurde hochgesetzt
20.05.2005 05:59:38	5	B.Kovacevic	SubVersion: QA Stufe wurde hochgesetzt	31.05.2005 14:50:14	4	B.Kovacevic	SubVersion: QA Stufe wurde hochgesetzt

eCATALOGsolutions

Bearbeitungszeit QA-Status:

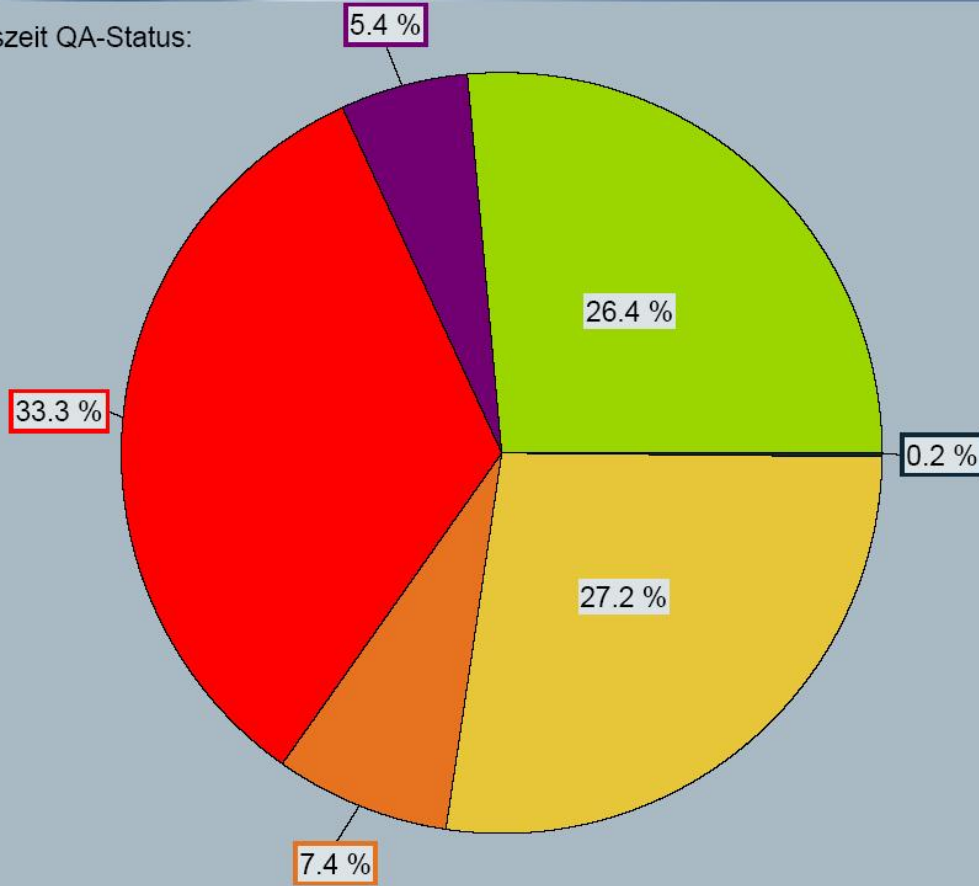

EXTRACT

Technologie Karosseriebau FM-Konstruktion
Knorrstrasse 147
80788 München
Tel: +49-89-382-47467
mailto:info@bmw.de
http://www.bmwgroup.com/

+ eCATSOL
Project Management will show project manager the bottle neck to get a better time-to-market

- QA-Bestätigung vom QA-Leiter (intern)
- Freigegeben zum Bearbeiten (vom Auftraggeber)
- In Bearbeitung
- QA-Bestätigung vom Bearbeiter
- Automatischen Test bestanden
- Noch nicht freigegeben

Marketing Power/ Market Position

Project Management & Single Source

Smart Parts & Processes

Printed Catalog

Assistant & Configurator

BMECAT & WebEDI

Paradigm Shifts

Geometrical Search

Collaboration

YIN – YANG Certified Catalogs CAX Data
„Harmony between Suppliers and Engineers“

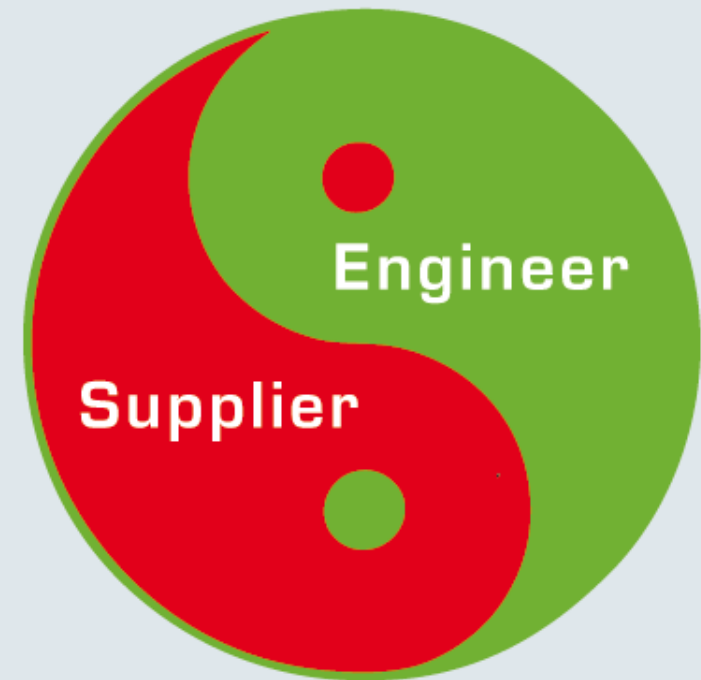

Supplier Data Management Requirements for a modern eCATALOG

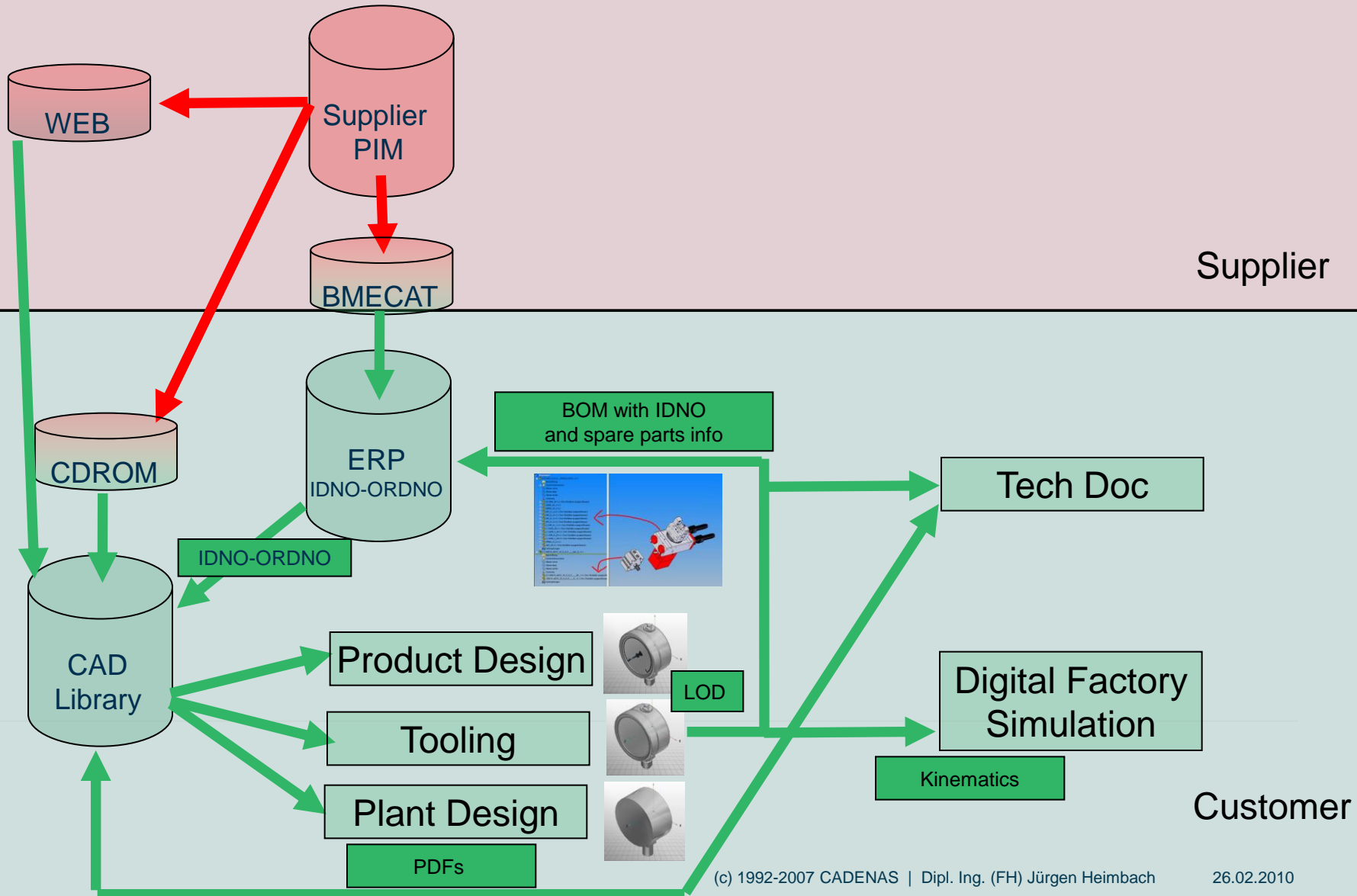

How do „Large Enterprises“ Work ? Controlled Versions/ Overview of Supplier Parts World

Engineering Finds A New Component

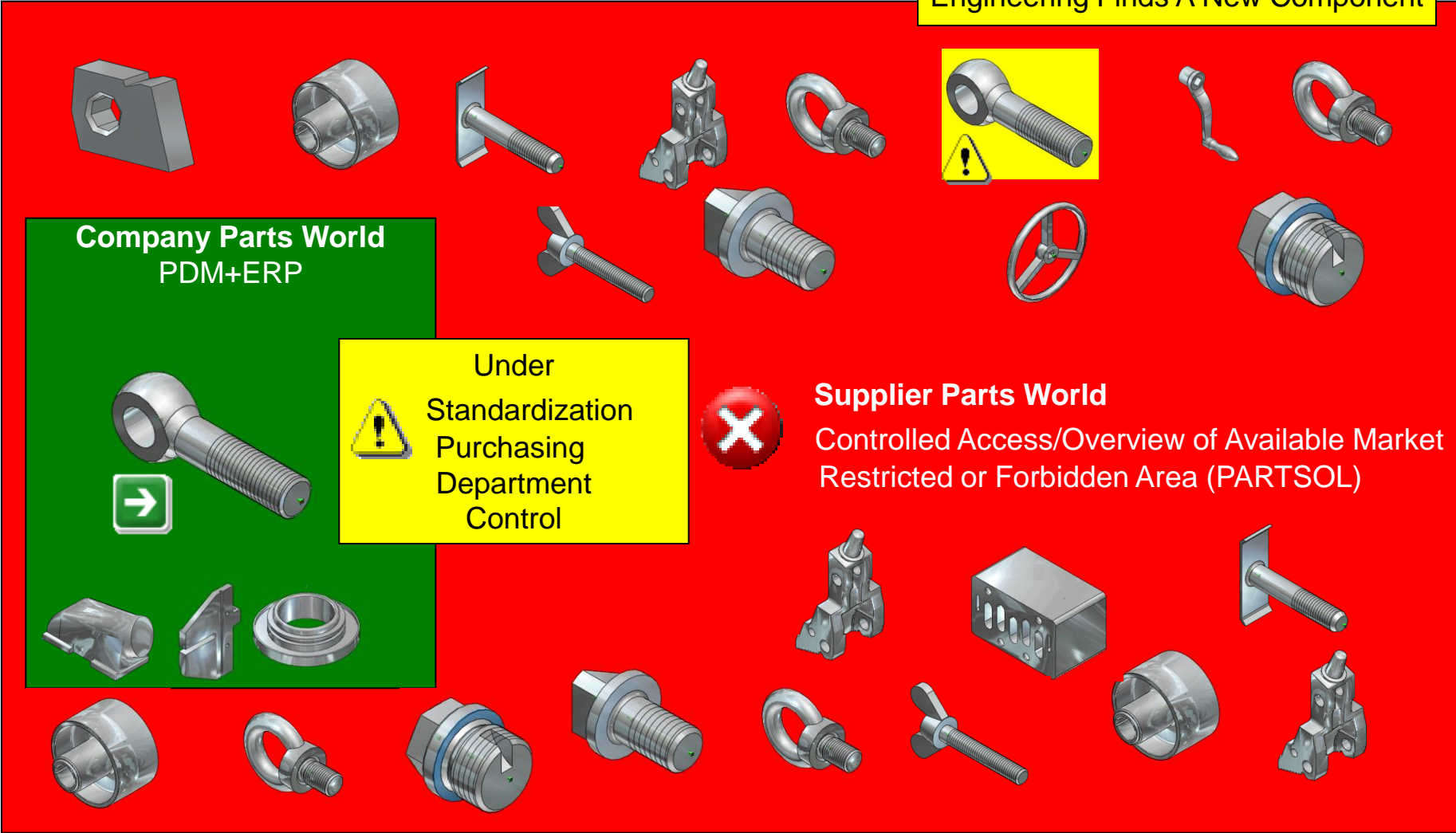

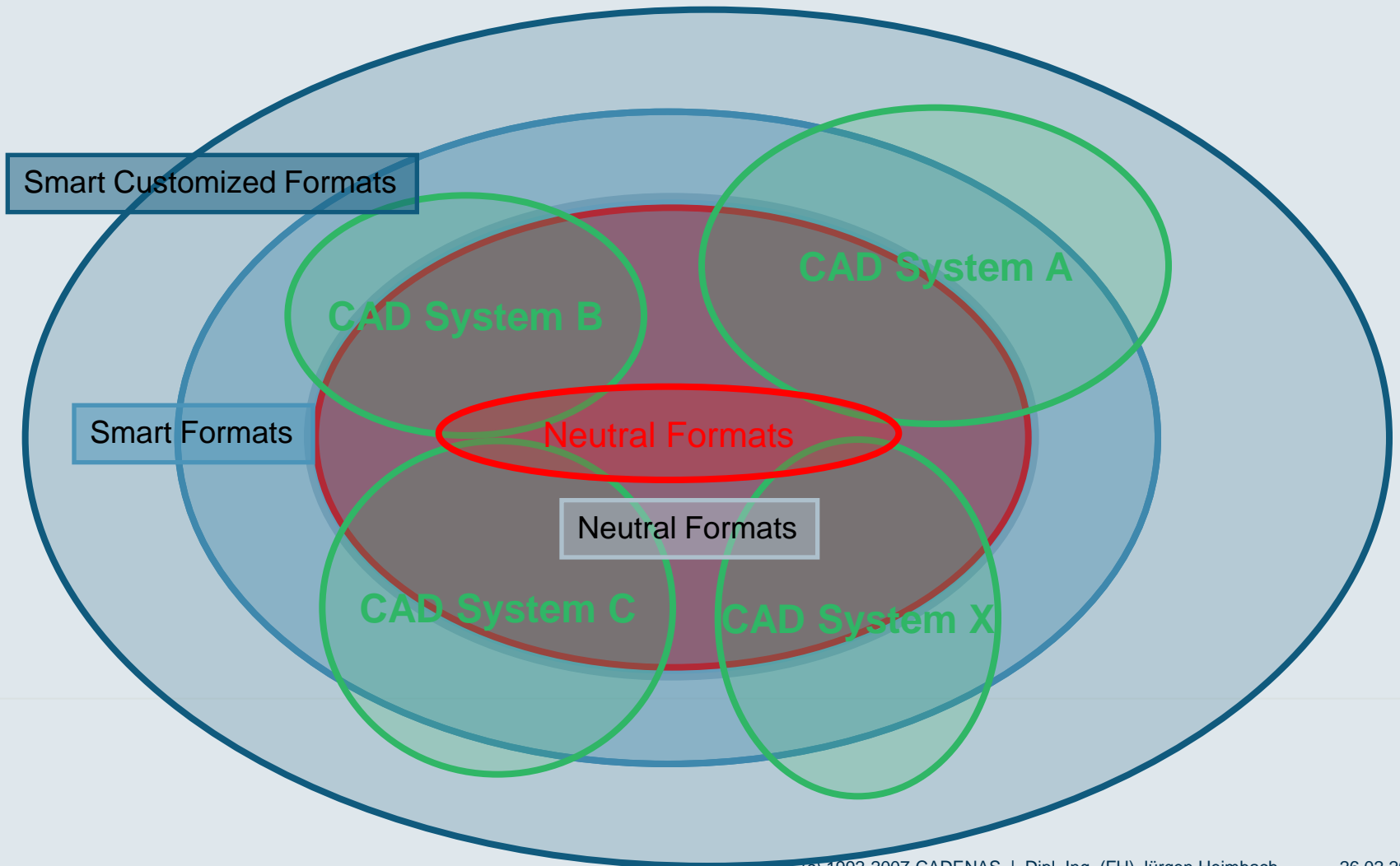

Example: BMW



Hallo Herr

ich habe mir am 22.11.2006 dieses Mod...

Wie Sie auf dem Bild sehen können, hat...
entspricht.

Die Qualität habe ich Ihnen beim ersten...
Für BMW unbrauchbar !!!

**Mail To Customer:
The Quality of the data is unusable**

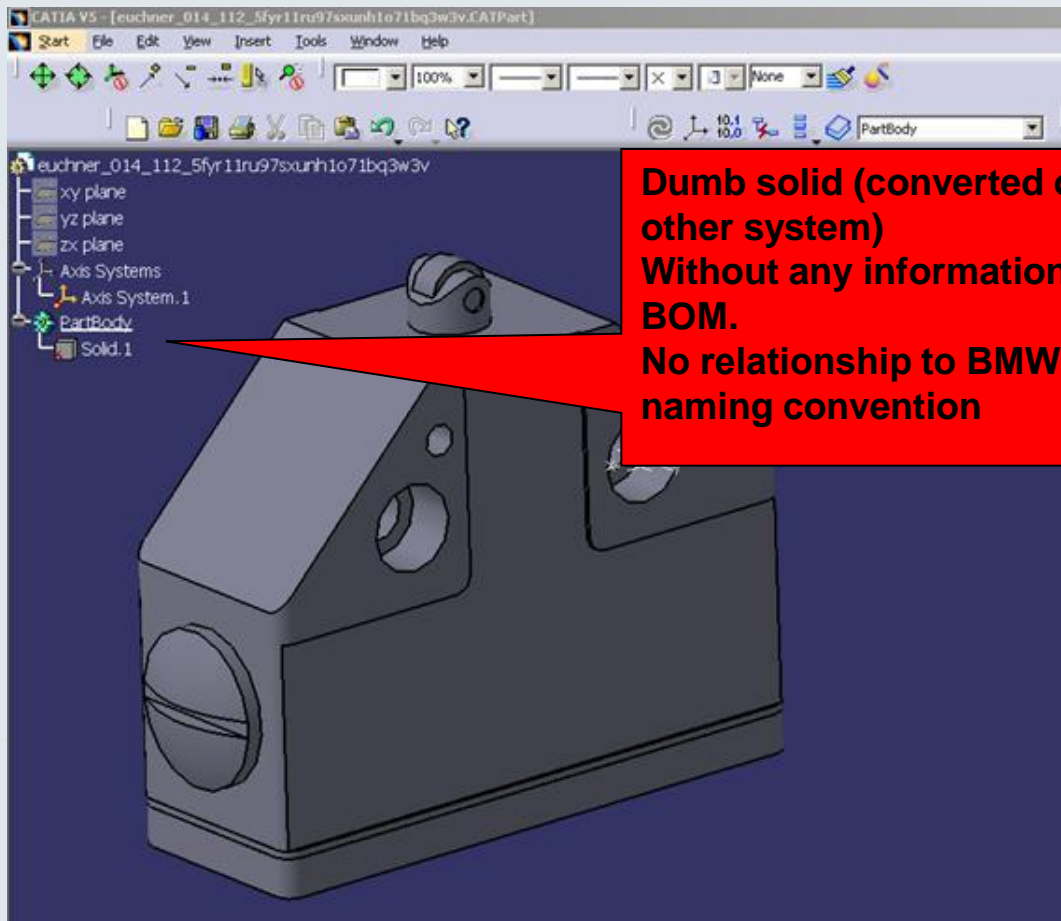

**Dumb solid (converted out of
other system)
Without any information for
BOM.
No relationship to BMW's
naming convention**

Results

- Data coming from STEP
will not be used @BMW

- Supplier risks losing their
frame agreement, or have to
create a second data
source through a CATIA
Consulting company

-Second dataset always results in
inconsistent data

-Maintenance of this data
Becomes a burden on the
Supplier

We received 250 parts from Festo with support from CADENAS. The result was acceptable for us.

Results

- The Data matches the Quality required for the BMW engineering process
- As a result, FESTO received a 10 year frame agreement @BMW

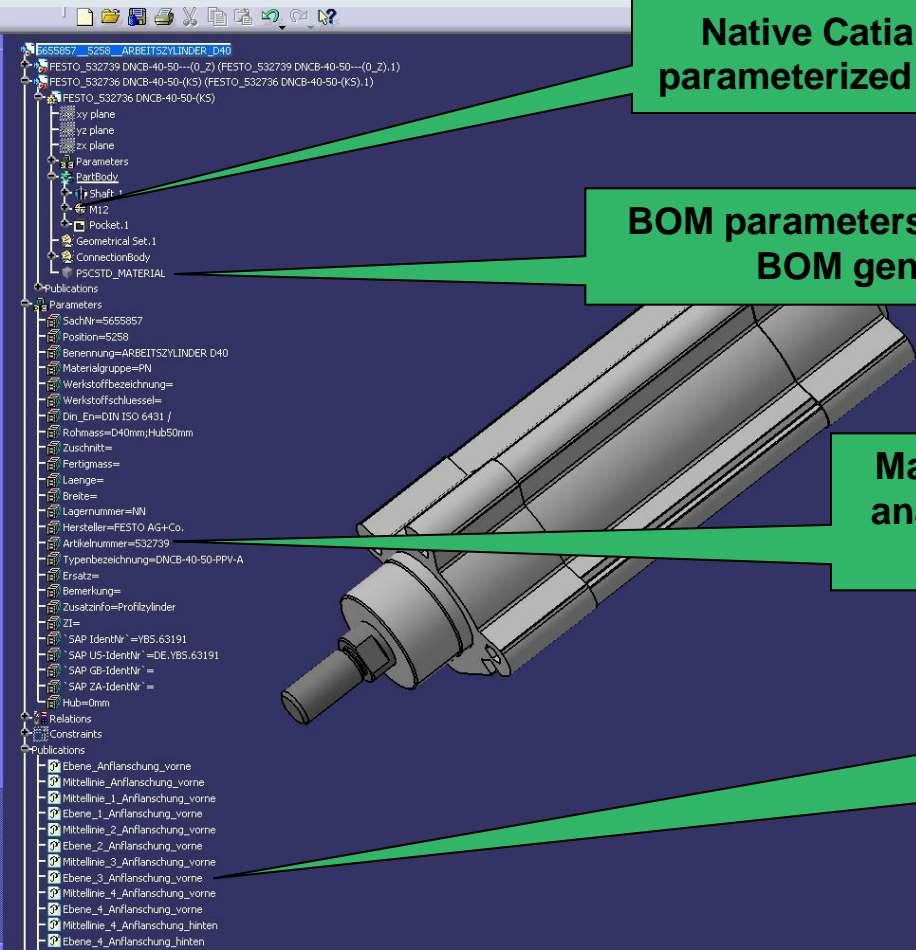

Native Catia V5 format parameterized and editable

BOM parameters for automatic BOM generation

Material parameters for weight analysis of the entire assembly

Publications for Connections. Entities providing reliable orientations inside the assembly, with the right constraints

Offers From Companies Who Serve The Same Market

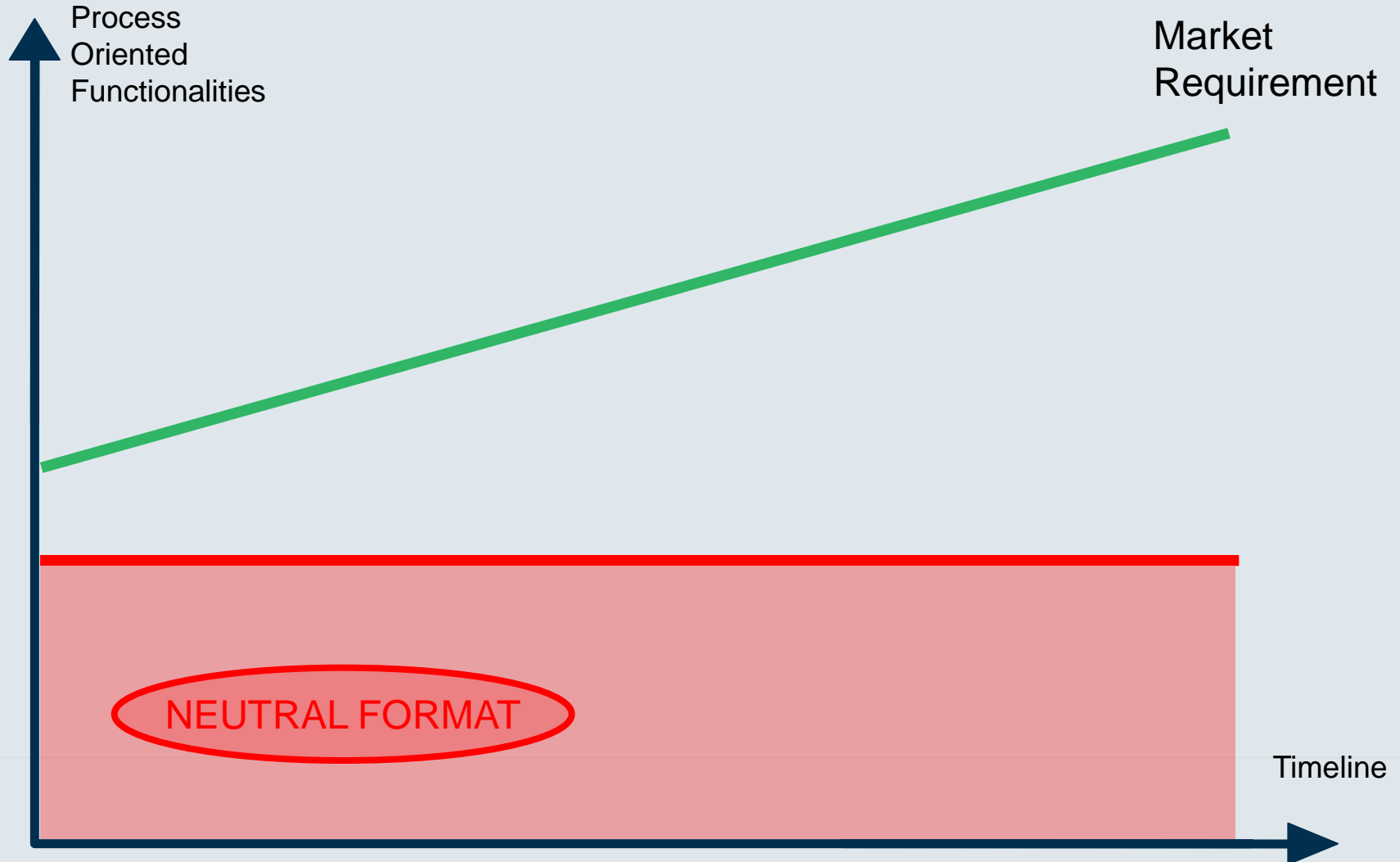

Unique Technology Of CADENAS /PARTsolutions

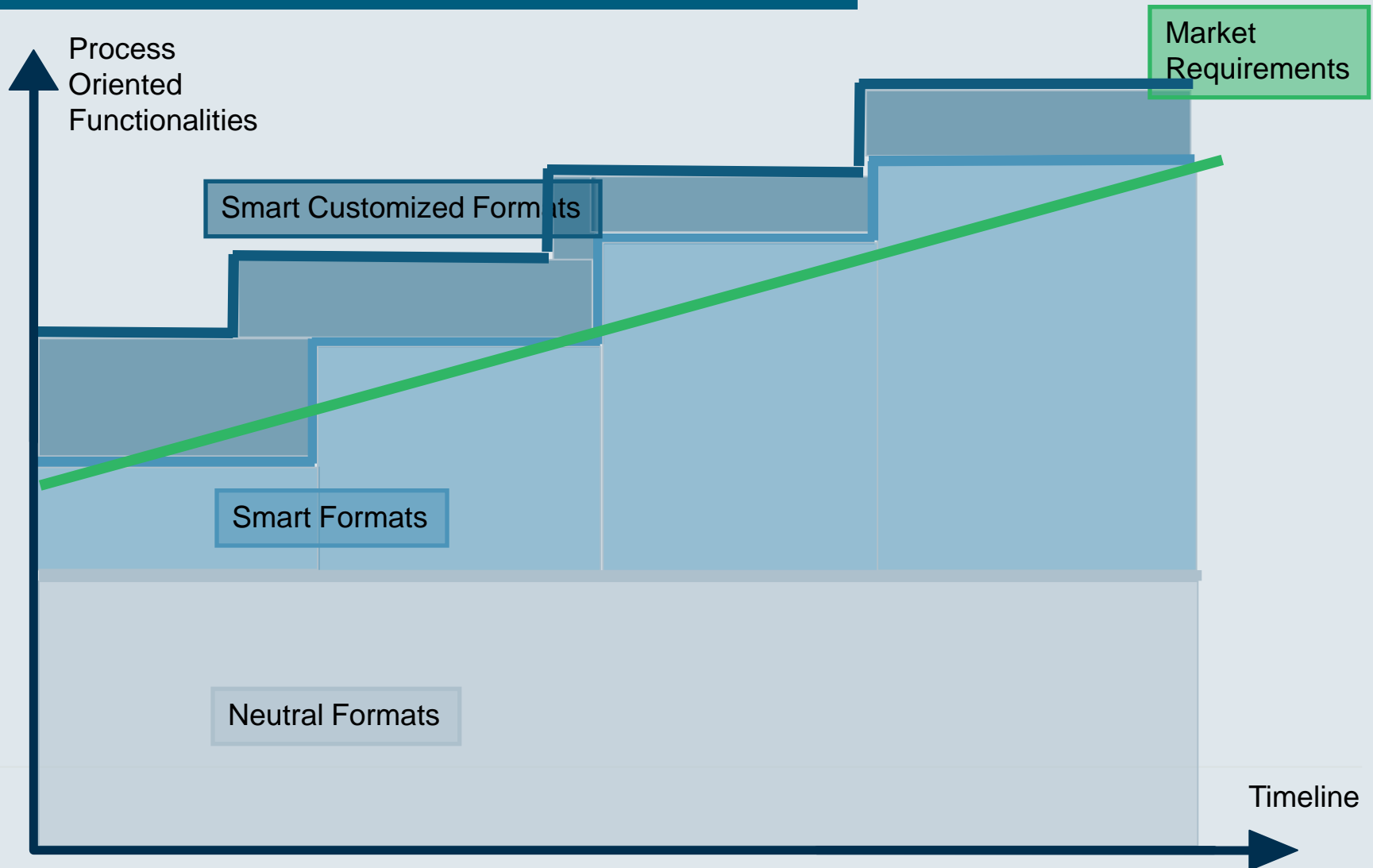



Internetplattform für Komponentenbibliotheken



Vergleich der Ist- und Soll Situation

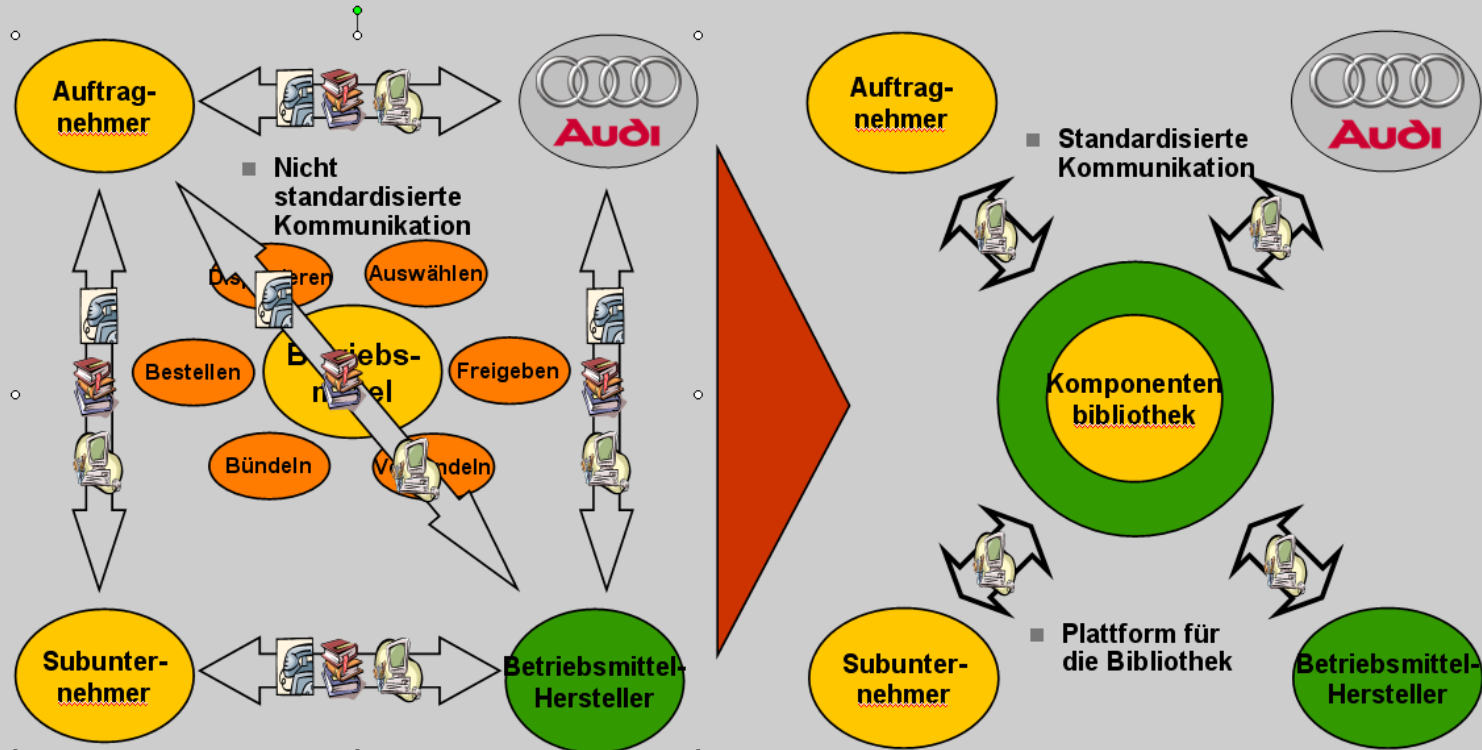



Directly Integrated in Supply.com

VW Group Supply.com

Where we integrate with our suppliers.



[Click here to start CADENAS ...](#)

© copyright CADENAS GmbH, PARTSolutions LLC

EXTRACT

+ Suppliers are forced to join the portal if they want to work any more for AUDI

+ Integrated in VW Group Supply.com 

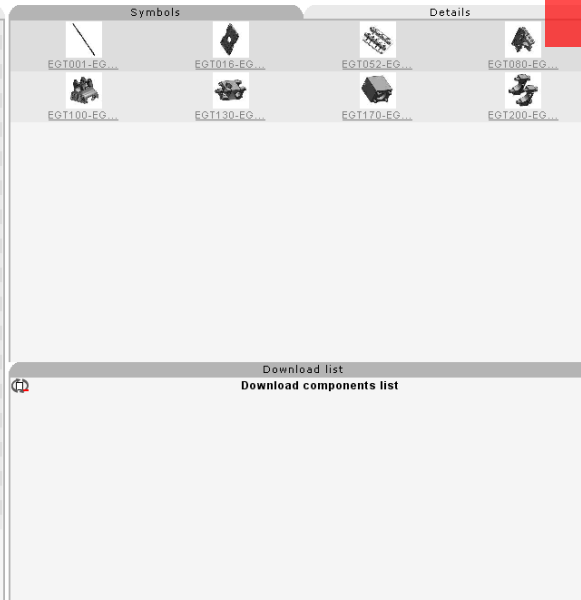
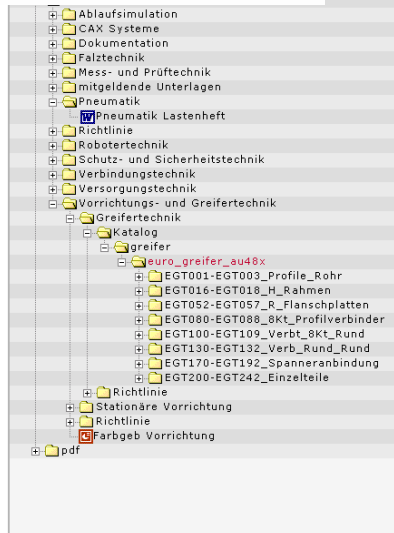



AIRBUS

AN EADS JOINT COMPANY WITH BAE SYSTEMS

Highlights:

PARTsolutions A Strategic Tool @ AIRBUS
 Every Airbus supplier of Jigs & Tools
 Is forced to deliver ist supplier catalog in
 eCATALOGsolutions format



PARTSOLUTIONS - A "MUST-HAVE" FOR ALL AIRBUS ENGINEERING SUPPLIERS

"Before creating a future, our customers expect the respective digital mock-up. Today PARTsolutions contains the bulk of required supplier data within manufacturer catalogs. The catalogs of all our suppliers should be available in PARTsolutions. PARTsolutions has streamlined collaboration with engineering service providers and enabled us to eliminate all data exchange problems."

Mr. Klaus Zache
 AIRBUS Deutschland GmbH



"After a very quick implementation of PARTsolutions parts management, our collaboration with Airbus has improved significantly. With PARTsolutions, we were able to achieve a quick head start in our business."

Mr. Bert Dalven, Engineer
 HARTWIG Spezialmaschinenbau GmbH

AIRBUS AND ITS SUPPLIERS SPEAK THE SAME »LANGUAGE«!



STANDARD PARTS, LIBRARIES

CATIA V5 libraries are required to utilize the Airbus numbering system 9.1.2. To achieve this requirement, Airbus uses PARTsolutions software and provides a selection of industry standard and supplier part catalogs for internal users. To ensure the integrity of the design process with its suppliers, access to the same libraries would be desired. To achieve this, AIRBUS provides this data to its suppliers via the aircraft.

PARTSOLUTIONS - A STRATEGIC TOOL AT AIRBUS

AIRBUS NUMBERING ACCORDING TO CAD GUIDELINE 9.1.2

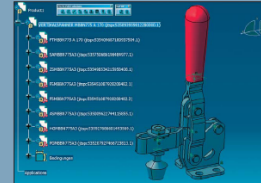

Due to a numbering and naming system specially developed for AIRBUS, engineering supplier also benefit from correct part numbers by using PARTsolutions.

AIRBUS BENEFITS:

- Time reduction for data retrieval in engineering
 - User friendly interface
 - Access to current data
 - Error free data exchange and creation
- Prevention of CATIA specific data exchange problems with engineering suppliers
- Central Administration
 - Reduced storage requirements
 - Centralized catalog updates
 - Easy user and license administration
- Reduced purchasing costs for industry standard and supplier parts

COMPONENT SUPPLIERS STRENGTHEN THE COLLABORATION WITH AIRBUS

STRATEGIC COMPONENT SUPPLIERS OF AIRBUS

Alpha	RIA	Häler-Vogel
ANF	Item	Kernroh
Bilke	Häler	Röh
Boch	MayTec	Keller GmbH
DE-STA-CO	MinTec	Rohfeld Spannsysteme
Emik Martin	Narf	Ros&Krieger
Europa	Franken Normalmetalle CHG	Schmalz
FAG	NSK	Schmalz
Festo AG & Co. KG	Otto Geyer GmbH & Co. KG	SEF
Fibre	Parker Ermao	Sier
Guckelast	Qui	Straubman Machine & Handing
Häber	Raboudin	THK
IGUS		and many more

Always provide their catalogs in PARTsolutions

By using eCATALOGsolutions to create your electronic part catalog you get worldwide exposure and distribution through PARTsolutions for existing and new customers, not just AIRBUS. Additionally, the multiple media outputs provided by eCATALOGsolutions allow you to service many departments of your customers, including purchasing, engineering, process planning, technical documentation, etc...



By enabling your catalog in PARTsolutions, you support this strategic AIRBUS supplier initiative, and open up new revenue opportunities with other customers, both existing and new. A solution for your entire customer base! PARTsolutions enterprise applications are used by more than 50,000 engineers for enterprise parts management and supplier integration, and by more than an additional 450,000 engineers via the internet.

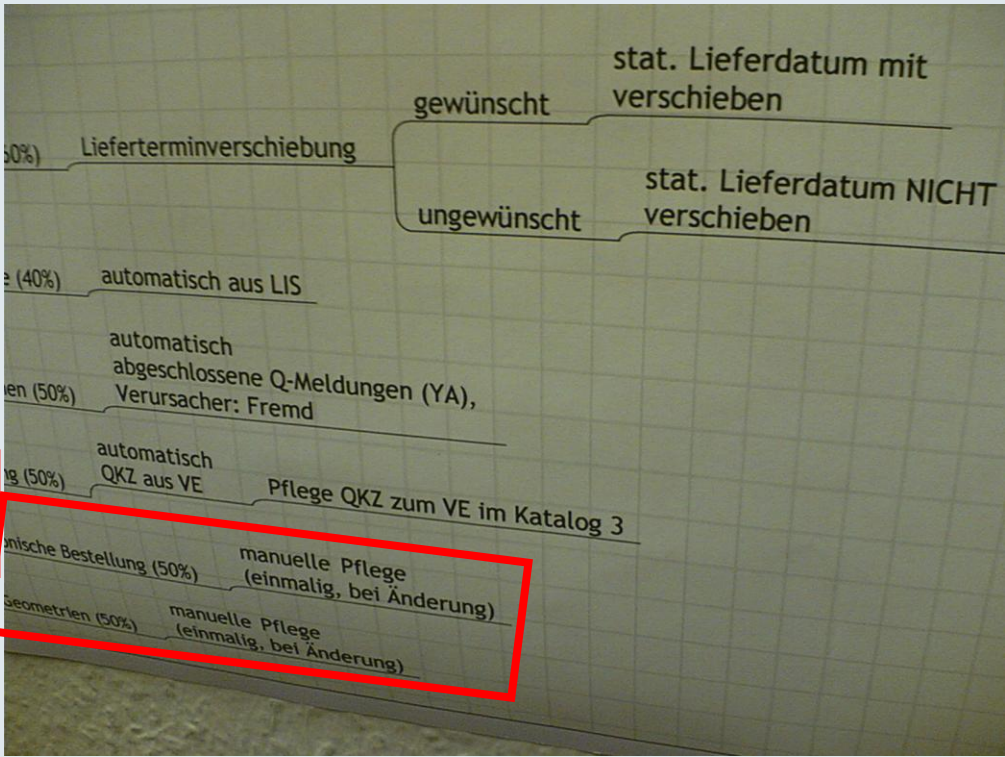
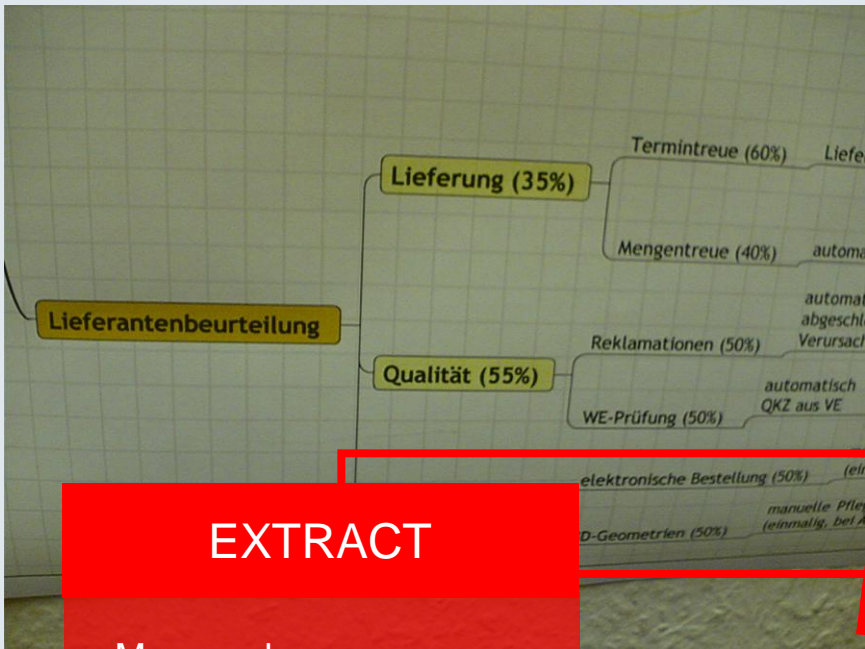

EXTRACT

+ More and more companies require smart CAD data as essential in their supplier rating

! No pricing is mentioned

Marketing Power/ Market Position

Project Management & Single Source

Smart Parts & Processes

Printed Catalog

Assistant & Configurator









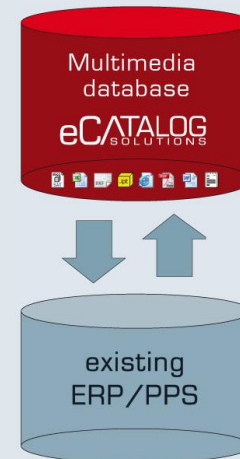



BMECAT & WebEDI

Paradigm Shifts

Geometrical Search

Collaboration



Output media:	
	▶ Web
	▶ CD-ROM
	▶ Print catalog
Improve your marketing:	
	▶ Product portals with over 2.8 million users
	▶ Supplier Parts Library PARTSolutions
	▶ Market places with BMEcat
	▶ e-Shop
Features:	
	▶ Product configurator
	▶ Customer Relationship Management
	▶ Document Management
	▶ Support Management
	▶ Market research

Current Situation: In many companies today „Island Solutions“ are used

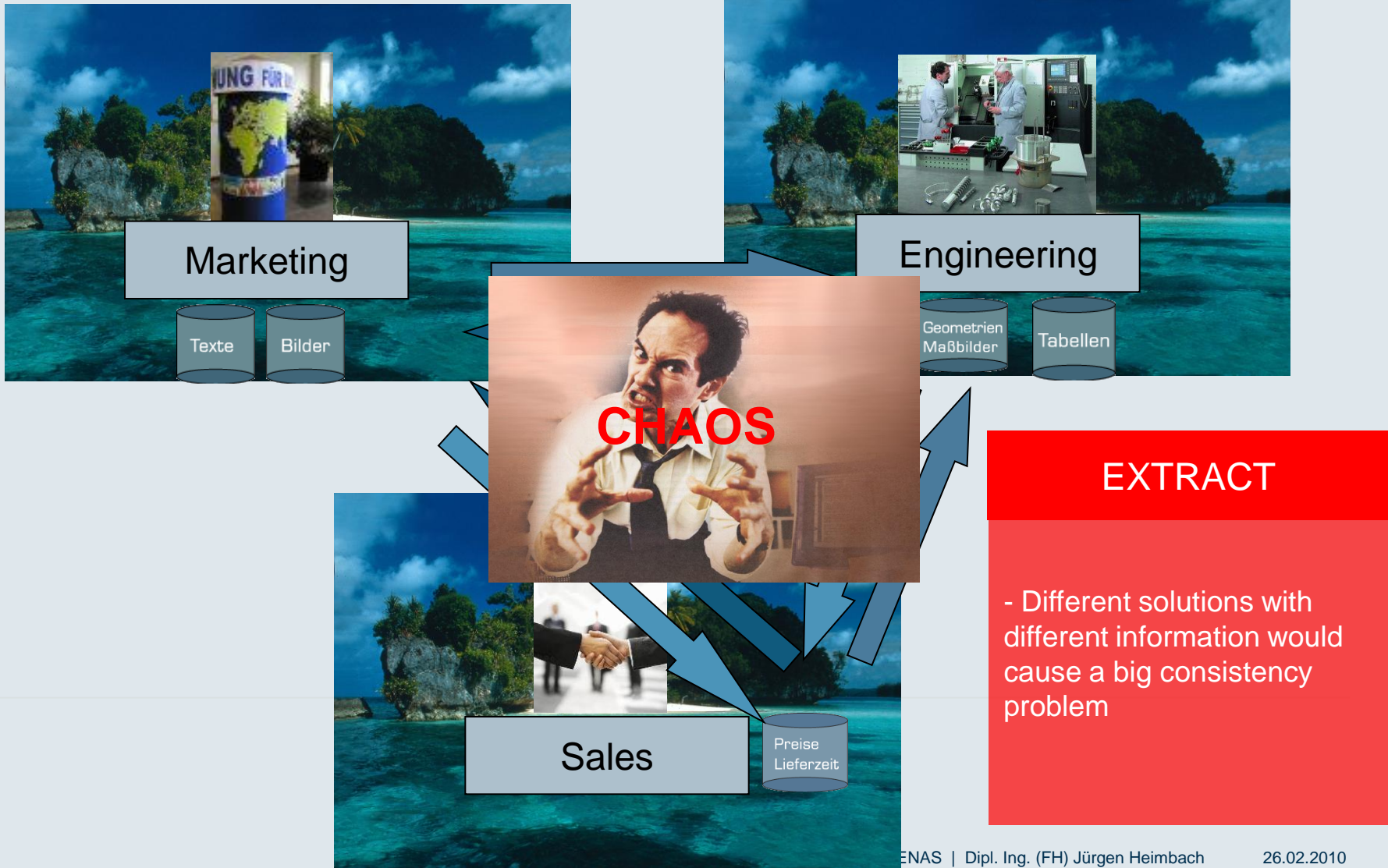

Why Is A Single Source DB Strategy So Important ? Where is the leading system ?

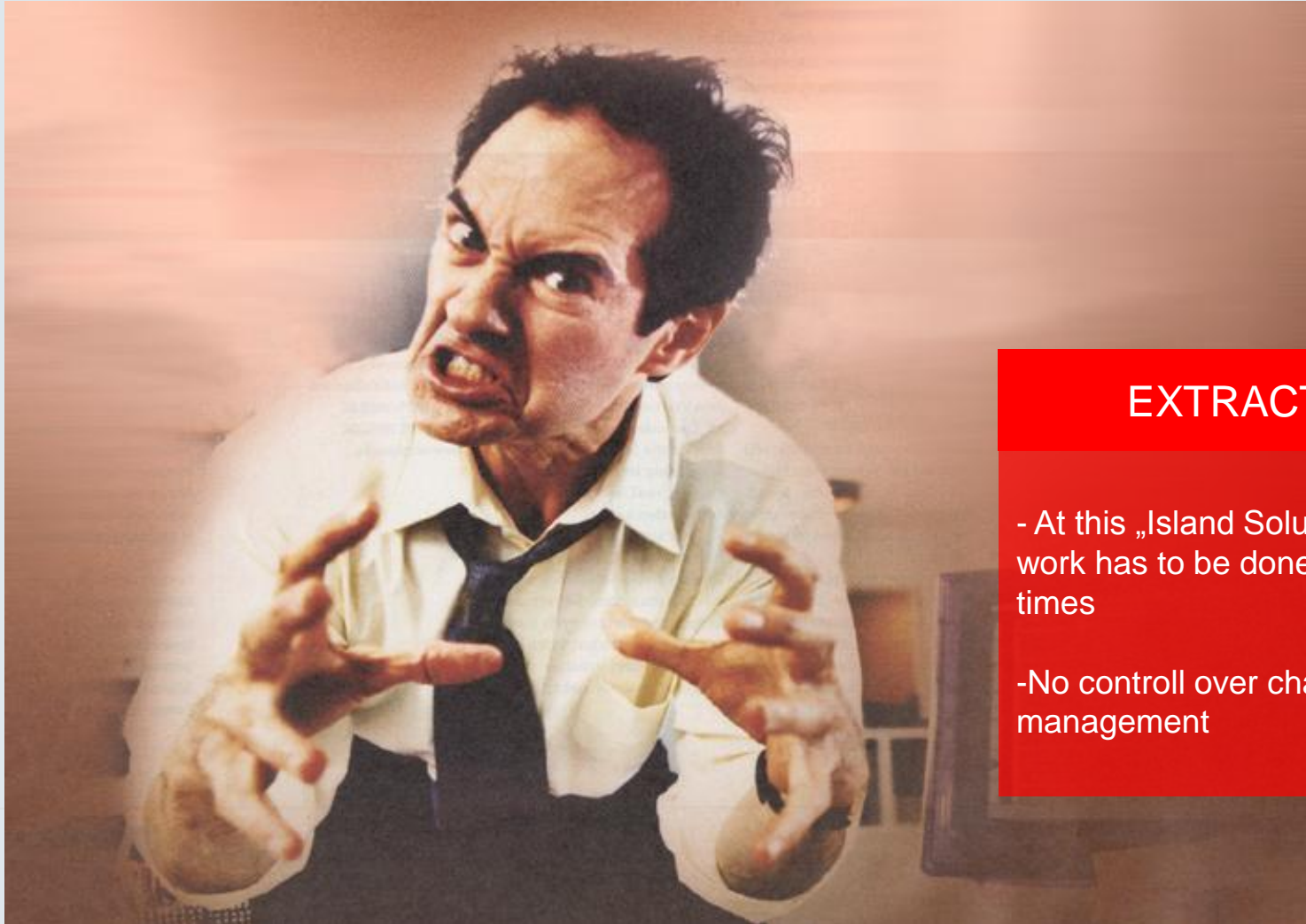

EXTRACT

- At this „Island Solutions“ work has to be done multiple times
- No controll over change management



Architecture eCATALOGsolutions/print

- EXTRACT
- + Multiple languages
- + Catalog will be in future done by 60% time reduction
- + Customer specific catalogs could be done very easily



Unternehmen : Produkte : Aktuelles : Downloads : Karriere : Kontakt

223. Schneidstempel DIN 9861 FORM D

223.

<p>Werkstoff:</p> <p>HSS Beil-Nummer 223.5 Härte 62±2 HRC Kopf 52±5 HRC</p> <p>MS Beil-Nummer 223.4 Härte 2900 MPa / 0,5 Kopf 52±5 HRC</p> <p>H2-Ti (HSS) Beil-Nummer 223.6 Härte 3200 MPa / 0,05 Kopf 52±5 HRC</p> <p>SP 20-KP 2023 Beil-Nummer 223.6 Härte 44±2 HRC Kopf 52±5 HRC</p> <p>Werkstoffbeschreibung und andere Werkstoffe, siehe Seite 2 oder 3 im K.</p> <p>Ausführung: Form D Der Stempelstempel wird nach dem Warmtischen und Anlassen der Stempelbohle im Erstarbereich in einseitig schließlichen Materialabtragungen unterhalb des Stempelkopfes werden dadurch benötigt und ein großer Rundstiel zwischen Stempelstempel und Stempelbohle einsetzt. Dadurch ist absolute Austauschbarkeit des Stempel Letztensatzes gegeben.</p>	<table border="1" style="width: 100%; border-collapse: collapse; font-size: 8px;"> <tr><th colspan="4">223.</th></tr> <tr><th>d₁</th><th>d₂</th><th>h</th><th>k</th></tr> <tr><td>0,5</td><td>0,9</td><td>0,2</td><td>0,2</td></tr> <tr><td>0,55</td><td>1,1</td><td>0,2</td><td>0,2</td></tr> <tr><td>0,6</td><td>1,3</td><td>0,2</td><td>0,2</td></tr> <tr><td>0,7</td><td>0,75</td><td>1,3</td><td>0,2</td></tr> <tr><td>0,8</td><td>0,85</td><td>1,4</td><td>0,4</td></tr> <tr><td>0,9</td><td>0,95</td><td>1,6</td><td>0,4</td></tr> <tr><td>1</td><td>1,1</td><td>1,8</td><td>0,5</td></tr> <tr><td>1,2</td><td>1,3</td><td>2</td><td>0,5</td></tr> <tr><td>1,4</td><td>1,6</td><td>2,2</td><td>0,5</td></tr> <tr><td>1,6</td><td>1,9</td><td>2,6</td><td>0,5</td></tr> <tr><td>1,8</td><td>1,9</td><td>2,8</td><td>0,5</td></tr> <tr><td>2</td><td>2,2</td><td>3,2</td><td>0,5</td></tr> <tr><td>2,3</td><td>2,5</td><td>3,5</td><td>0,5</td></tr> <tr><td>2,5</td><td>2,5</td><td>4</td><td>0,5</td></tr> <tr><td>3</td><td>3,4</td><td>4,5</td><td>0,5</td></tr> <tr><td>3,5</td><td>3,5</td><td>5</td><td>0,5</td></tr> <tr><td>4</td><td>4,4</td><td>5,5</td><td>0,5</td></tr> <tr><td>4,5</td><td>4,5</td><td>6</td><td>0,5</td></tr> <tr><td>5</td><td>5,4</td><td>6,5</td><td>0,5</td></tr> <tr><td>5,5</td><td>5,5</td><td>7</td><td>0,5</td></tr> <tr><td>6</td><td>6,4</td><td>8</td><td>0,5</td></tr> <tr><td>6,5</td><td>6,5</td><td>8,5</td><td>0,5</td></tr> <tr><td>7</td><td>7,4</td><td>9</td><td>0,5</td></tr> <tr><td>7,5</td><td>7,5</td><td>10</td><td>0,5</td></tr> <tr><td>8</td><td>8,4</td><td>11</td><td>0,5</td></tr> <tr><td>8,5</td><td>8,5</td><td>12</td><td>0,5</td></tr> <tr><td>9</td><td>9,4</td><td>13</td><td>0,5</td></tr> <tr><td>9,5</td><td>9,5</td><td>14</td><td>0,5</td></tr> <tr><td>10</td><td>10,4</td><td>15</td><td>0,5</td></tr> <tr><td>10,5</td><td>10,5</td><td>16</td><td>0,5</td></tr> <tr><td>11</td><td>11,4</td><td>17</td><td>0,5</td></tr> <tr><td>11,5</td><td>11,5</td><td>18</td><td>0,5</td></tr> <tr><td>12</td><td>12,4</td><td>19</td><td>0,5</td></tr> <tr><td>12,5</td><td>12,5</td><td>20</td><td>0,5</td></tr> <tr><td>13</td><td>13,4</td><td>21</td><td>0,5</td></tr> <tr><td>13,5</td><td>13,5</td><td>22</td><td>0,5</td></tr> </table>	223.				d ₁	d ₂	h	k	0,5	0,9	0,2	0,2	0,55	1,1	0,2	0,2	0,6	1,3	0,2	0,2	0,7	0,75	1,3	0,2	0,8	0,85	1,4	0,4	0,9	0,95	1,6	0,4	1	1,1	1,8	0,5	1,2	1,3	2	0,5	1,4	1,6	2,2	0,5	1,6	1,9	2,6	0,5	1,8	1,9	2,8	0,5	2	2,2	3,2	0,5	2,3	2,5	3,5	0,5	2,5	2,5	4	0,5	3	3,4	4,5	0,5	3,5	3,5	5	0,5	4	4,4	5,5	0,5	4,5	4,5	6	0,5	5	5,4	6,5	0,5	5,5	5,5	7	0,5	6	6,4	8	0,5	6,5	6,5	8,5	0,5	7	7,4	9	0,5	7,5	7,5	10	0,5	8	8,4	11	0,5	8,5	8,5	12	0,5	9	9,4	13	0,5	9,5	9,5	14	0,5	10	10,4	15	0,5	10,5	10,5	16	0,5	11	11,4	17	0,5	11,5	11,5	18	0,5	12	12,4	19	0,5	12,5	12,5	20	0,5	13	13,4	21	0,5	13,5	13,5	22	0,5
223.																																																																																																																																																									
d ₁	d ₂	h	k																																																																																																																																																						
0,5	0,9	0,2	0,2																																																																																																																																																						
0,55	1,1	0,2	0,2																																																																																																																																																						
0,6	1,3	0,2	0,2																																																																																																																																																						
0,7	0,75	1,3	0,2																																																																																																																																																						
0,8	0,85	1,4	0,4																																																																																																																																																						
0,9	0,95	1,6	0,4																																																																																																																																																						
1	1,1	1,8	0,5																																																																																																																																																						
1,2	1,3	2	0,5																																																																																																																																																						
1,4	1,6	2,2	0,5																																																																																																																																																						
1,6	1,9	2,6	0,5																																																																																																																																																						
1,8	1,9	2,8	0,5																																																																																																																																																						
2	2,2	3,2	0,5																																																																																																																																																						
2,3	2,5	3,5	0,5																																																																																																																																																						
2,5	2,5	4	0,5																																																																																																																																																						
3	3,4	4,5	0,5																																																																																																																																																						
3,5	3,5	5	0,5																																																																																																																																																						
4	4,4	5,5	0,5																																																																																																																																																						
4,5	4,5	6	0,5																																																																																																																																																						
5	5,4	6,5	0,5																																																																																																																																																						
5,5	5,5	7	0,5																																																																																																																																																						
6	6,4	8	0,5																																																																																																																																																						
6,5	6,5	8,5	0,5																																																																																																																																																						
7	7,4	9	0,5																																																																																																																																																						
7,5	7,5	10	0,5																																																																																																																																																						
8	8,4	11	0,5																																																																																																																																																						
8,5	8,5	12	0,5																																																																																																																																																						
9	9,4	13	0,5																																																																																																																																																						
9,5	9,5	14	0,5																																																																																																																																																						
10	10,4	15	0,5																																																																																																																																																						
10,5	10,5	16	0,5																																																																																																																																																						
11	11,4	17	0,5																																																																																																																																																						
11,5	11,5	18	0,5																																																																																																																																																						
12	12,4	19	0,5																																																																																																																																																						
12,5	12,5	20	0,5																																																																																																																																																						
13	13,4	21	0,5																																																																																																																																																						
13,5	13,5	22	0,5																																																																																																																																																						

Bestell-Beispiel:

Werkstoff	HSS	= 223
Werkstoff	MS	= 223
Schneidmesser	4 mm	= 0400
d ₁	0,5 mm	= 0500
länge	11 mm	= 011
Beil-Nummer		= 223.0.0400.011

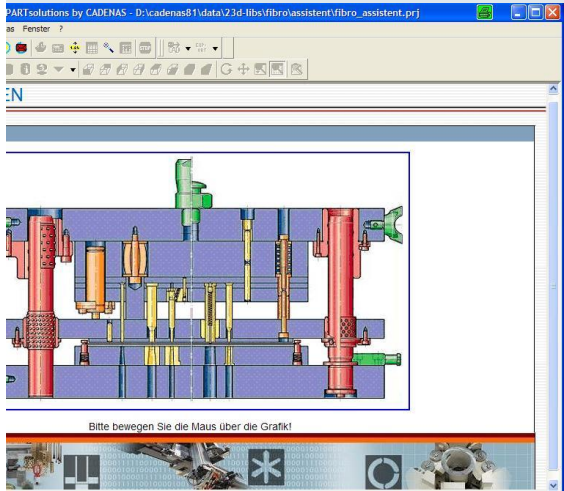

Adobe InDesign CS2 - [fxba_fxbx.indd @ 115% [Überdruckenvorschau]]

File Edit Window Help CADENAS

Tahoma Regular 7 Pt 9 Pt 100% 100% Fleshtext

Cantilever Shafts - Stepped Shafts - Retaining Ring Groove

Double stepped and Ring Grooves

FXBA PFXBA SFXBA HFXBA PHFXBA

Part No.	D	D _{gr}	Y 1mm Increment	F 1mm Increment	L	V	H	W	d Basic Size	d Tolerance	m	n
FXBA3-7-F3	3	-0.002			5	7	5	2		+0.060	0.5	
FXBA3A-7-F3	3	-0.008			9	11	9	2		0		
FXBA4-7-F3	4		7-30	3-50	12	6	8	6				2
FXBA4A-7-F3	4	-0.004			7	9	7					
FXBA5-7-F3	5				11	13	11	4		+0.075	0.7	
FXBA5A-7-F3	5	-0.012			8	10	8	5		0		
FXBA6-7-F3	6				12	14	12					
FXBA6A-7-F3	6	-0.005			10	12	10	7		+0.090	0.9	
FXBA7-7-F3	7	-0.014			15	17	14			0		
FXBA7A-7-F3	7	-0.014			13	15	13			-0.110	1.1	
FXBA8-7-F3	8		7-60	5-100	18	20	17	9.6				3
FXBA8A-7-F3	8	-0.005			14	16	14					
FXBA9-7-F3	9	-0.017			15	17	14	11.5				
FXBA9A-7-F3	9	-0.017			18	20	17	14.3				
FXBA10-7-F3	10				20	22	19	16.2				4
FXBA12-7-F3	12	-0.007			24	26	24	19				
FXBA17-7-F3	17	-0.007			29	31	27	23.9			1.36	
FXBA20-7-F3	20	-0.020			34	36	32	28.6		-0.210	1.66	5
FXBA25-7-F3	25		7-75									
FXBA30-7-F3	30											

Double stepped and Ring Grooves

FXBB PFXBB SFXBB HFXBB PHFXBB

Part No.	D	D _{gr}	Y 1mm Increment	F 1mm Increment	MA	L	V	H	W	M Coarse Thread
FXBB6-7-F5-MA3	6	-0.004		5-100	3	12	8	10	8	M6
FXBB6A-7-F5-MA3	6	-0.012				12	14	12		M8
FXBB7-7-F7-MA4	7		7-60	7-100	4	14	14	16	14	M8
FXBB7A-7-F7-MA4	7	-0.005				13	15	13		M10
FXBB8-7-F7-MA4	8	-0.014			4,5,6	18	20	17		M10
FXBB10A-7-F7-MA4	10					18	20	17		M12
FXBB12-7-F10-MA5	12	-0.006		10-150	5,6,8	17	15	17	14	M12
FXBB15-7-F12-MA6	15	-0.017			6,8,10	18	20	17		M16
FXBB17-7-F12-MA6	17	-0.017		12-150	5,6,8,10,12	19	20	22	19	M16
FXBB20-7-F12-MA6	20					24	26	24		M20
FXBB25-7-F17-MA8	25	-0.007		7-75	8,10,12,16	29	31	27		M20
FXBB30-7-F17-MA8	30	-0.020				34	36	32		M24

PARTcreatorprint

Vorlagen Eigenschaften Generieren Aktualisieren Log Voreinstell

fxba Tabelle

Grundeinstellungen

Tabellen Name:

Spalten .. Spalten des Projektes holen ERP Sichtbar Alle

Spalte	Titel	Format	Breite in
PN	\$desc.	<font style=nomnummer...	13.93
D	\$desc.		4.11
DTOL	D_g/_h		6.83
Y	Y 1mm $\langle b \rangle$Increment		10.61
F	F 1mm $\langle b \rangle$Increment		10.44
L	\$desc.		5.04
VS	V		5.02
H	\$desc.		4.83
W	\$desc.		5.78
DD	\$desc.		11.57
DDTOL	\$desc.		11.30
NN	\$desc.		5.86
M	\$desc.		
-YTOL	\$desc.		
-ALT1	\$desc.		
-HARD	\$desc.		
-MAT	\$desc.		
-ST	\$desc.		
-ALT2	\$desc.		

Alle Reihen zusammenfassen

Reihen zusammenfassen:

Dupliz. ... Zusatz ... Inhalt i. ... Ersatz

Zeilen sortieren

Spalte

Anpassungen

Minimale Anzahl Zeilen

An Framegröße

Gleiche Zeilen:

Spalten und Zeilen

Rahmen an Inhalt

Einschränkungen

Tabelle auflösen

Tabelle auflösen

Diese Spalten nicht FN,D.DTOL,Y,F,L,H,W,DD

Übernehmen





EXTRACT

+ Save money instead of producing expensive real pictures

+ New Corporate Design is easy to allocate

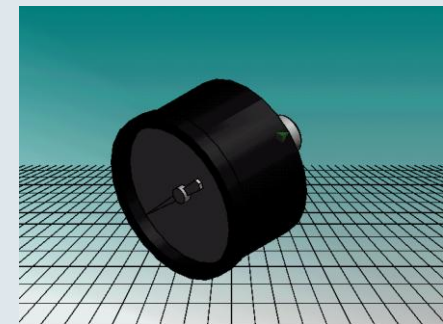
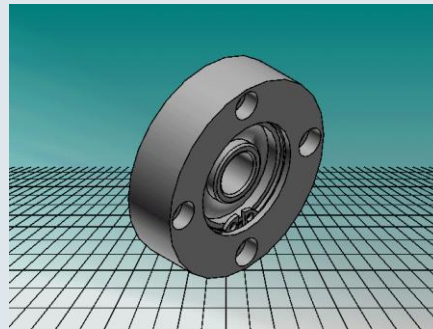
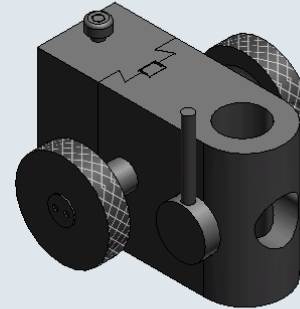
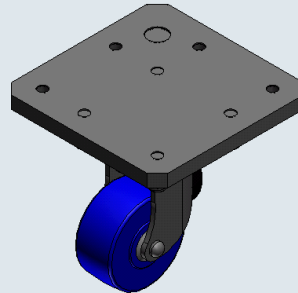
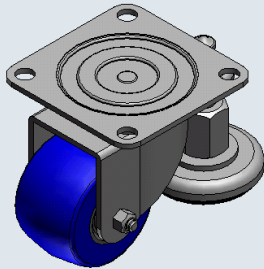

EXTRACT

- + Easy to generate
- + Working in every application
- + Easy way to show customer components @web

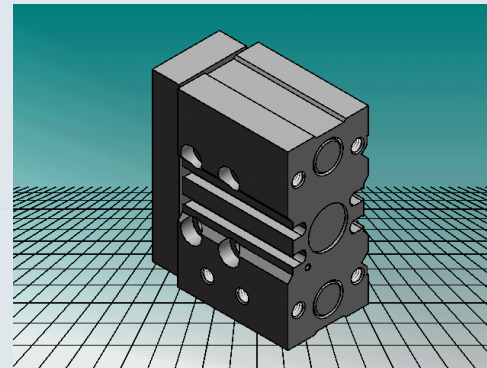



Use CAD Data Inside MS Products

EXTRACT

+ Embedding of 3D geometry
gives customer a
overview and un

Festo

Norm

AHP

Adobe Acrobat 3D

Part of the Acrobat family >

Publish, share, review, and mark up 3D designs in Intelligent Documents

Adobe® Acrobat® 3D software enriches collaboration by enabling extended teams to use Adobe PDF documents to more securely and reliably communicate 3D design intent. Insert and publish 3D designs from major CAD applications in Adobe PDF documents that can easily be shared with suppliers, partners, and customers using free Adobe Reader® 7.0 software.



order

Announcements

Download Acrobat 3D Update

This free download provides support for more recent versions of CAD file formats for Adobe Acrobat 3D and the 3D Toolkit.

Adobe Acrobat 3D Version 8

Learn about the exciting new features of Acrobat 3D.

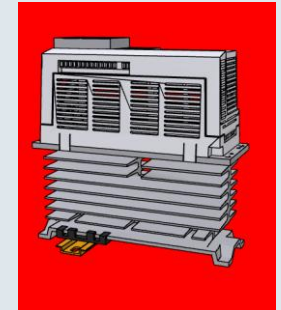

EXTRACT

- + Supporting a new standard
- + Embedding of 3D geometry gives customer a faster overview and understanding of your product

Marketing Power/ Market Position

Project Management & Single Source

Smart Parts & Processes

Printed Catalog

Assistant & Configurator

BMECAT & WebEDI

Paradigm Shifts

Geometrical Search

Collaboration

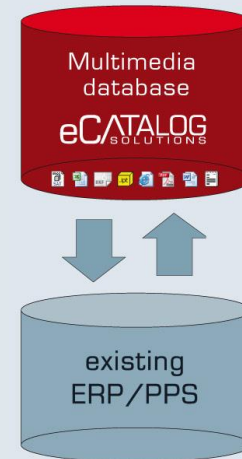

Output media:	
	▶ Web
	▶ CD-ROM
	▶ Print catalog
Improve your marketing:	
	▶ Product portals with over 2.8 million users
	▶ Supplier Parts Library PARTSolutions
	▶ Market places with BMEcat
	▶ e-Shop
Features:	
	▶ Product configurator
	▶ Customer Relationship Management
	▶ Document Management
	▶ Support Management
	▶ Market research

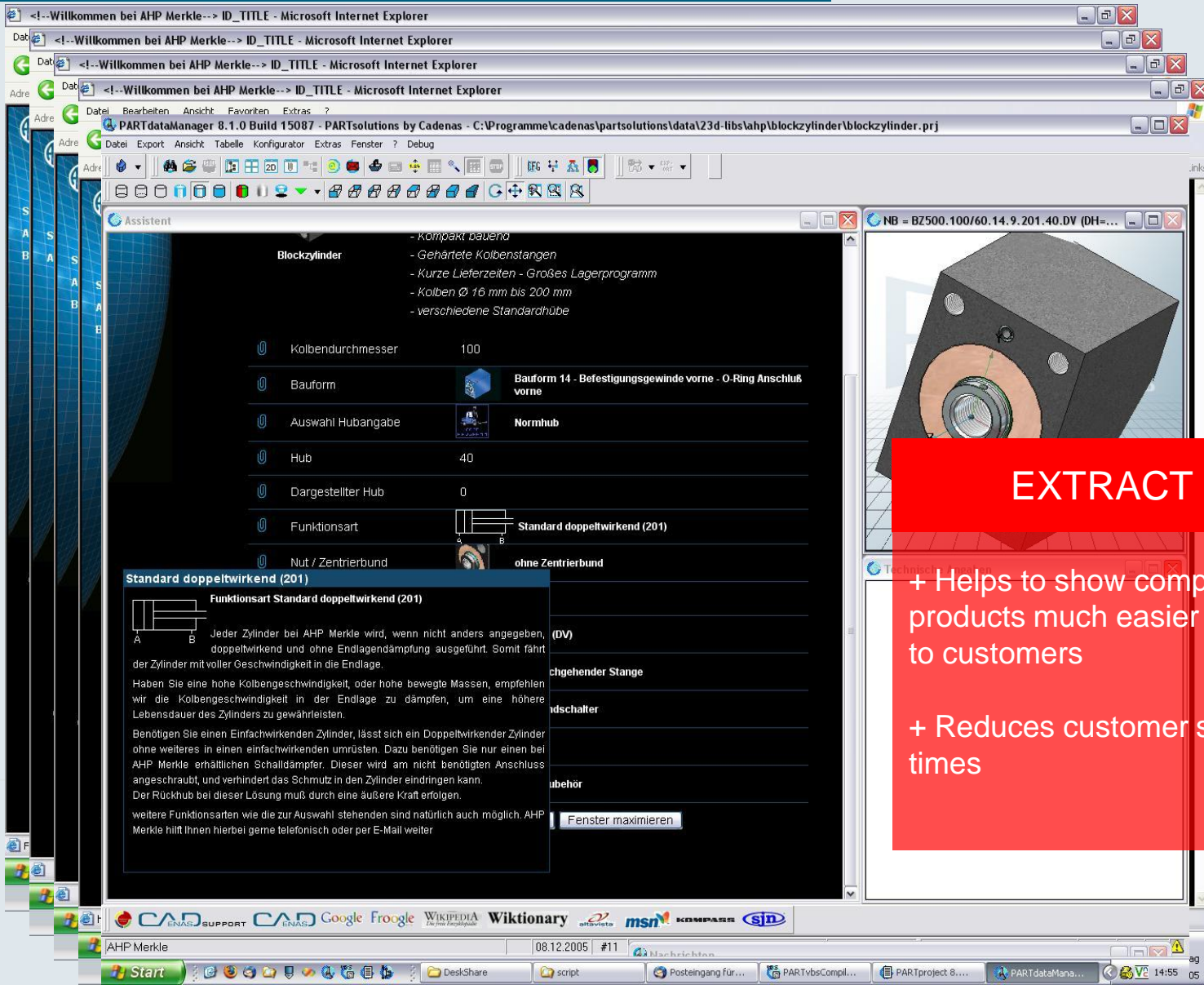

Blockzylinder

- kompakt bauend
- Gehärtete Kolbenstangen
- kurze Lieferzeiten - Großes Lagerprogramm
- Kolben Ø 16 mm bis 200 mm
- verschiedene Standardhübe

Kolbendurchmesser	100
Bauform	Bauform 14 - Befestigungsgewinde vorne - O-Ring Anschluss vorne
Auswahl Hubangabe	Normhub
Hub	40
Dargestellter Hub	0
Funktionsart	Standard doppelwirkend (201)
Nut / Zentrierbund	ohne Zentrierbund

Standard doppelwirkend (201)

Funktionsart Standard doppelwirkend (201)

Jeder Zylinder bei AHP Merkle wird, wenn nicht anders angegeben, doppelwirkend und ohne Endlagendämpfung ausgeführt. Somit fährt der Zylinder mit voller Geschwindigkeit in die Endlage.

Haben Sie eine hohe Kolbengeschwindigkeit, oder hohe bewegte Massen, empfehlen wir die Kolbengeschwindigkeit in der Endlage zu dämpfen, um eine höhere Lebensdauer des Zylinders zu gewährleisten.

Benötigen Sie einen Einfachwirkenden Zylinder, lässt sich ein Doppelwirkender Zylinder ohne weiteres in einen einfachwirkenden umrüsten. Dazu benötigen Sie nur einen bei AHP Merkle erhältlichen Schalldämpfer. Dieser wird am nicht benötigten Anschluss angeschraubt, und verhindert das Schmutz in den Zylinder eindringen kann. Der Rückhub bei dieser Lösung muß durch eine äußere Kraft erfolgen.



weitere Funktionsarten wie die zur Auswahl stehenden sind natürlich auch möglich. AHP Merkle hilft Ihnen hierbei gerne telefonisch oder per E-Mail weiter.

EXTRACT

- + Helps to show complexer products much easier to customers
- + Reduces customer support times

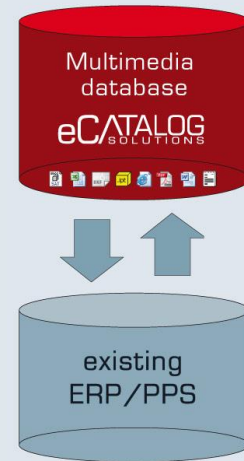
- Marketing Power/ Market Position
- Project Management & Single Source
- Smart Parts & Processes
- Printed Catalog
- Assistant & Configurator
- BMECAT & WebEDI**
- Paradigm Shifts
- Geometrical Search
- Collaboration



Output media:	
	▶ Web
	▶ CD-ROM
	▶ Print catalog
Improve your marketing:	
	▶ Product portals with over 2.8 million users
	▶ Supplier Parts Library PARTSolutions
	▶ Market places with BMEcat
	▶ e-Shop
Features:	
	▶ Product configurator
	▶ Customer Relationship Management
	▶ Document Management
	▶ Support Management
	▶ Market research

▶ **ARIBA**



www.ariba.org

▶ **click2procure**



www.click2procure.com

▶ **Commerce One**



www.commerceone.com

▶ **Covisint**



www.covisint.com

▶ **Direct Industry**



www.directindustry.com

▶ **EC4EC**



www.ec4ec.com

▶ **KEM**



www.kem.de

▶ **Newtron**



www.newtron.net

▶ **Simple System**



www.simplesystem.de

▶ **sjn**



www.sjn.de

▶ **Sourcing Parts**



www.sourcingparts.com

▶ **SupplyOn**



www.supplyon.com

▶ **VDMA**



www.vdma-e-market.com

▶ **Verticalnet**



www.verticalnet.com

▶ **VW Group Supply**



www.vwgroupsupply.com

Implementierung von eShop

eShop-Werke

- Hamburg
- Bremen
- Berlin
- Kassel
- Düsseldorf
- Mannheim
- Wörth
- Germersheim
- Rastatt
- Gaggenau
- Sindelfingen
- Zentrale (00/96)
- Untertürk. (10)
- Kölleda

eShop-Gesellschaften

- EvoBus (Ulm, Mannh.)
- DCVD
- debeos
- DC Südafrika

eShop Statistik 2002 - 2004

	2002	2003	2004
Anwender	1.300	3.000	5.500
Abrufe	52.000	69.400	140.000
elektronische Kataloge	30	72	108

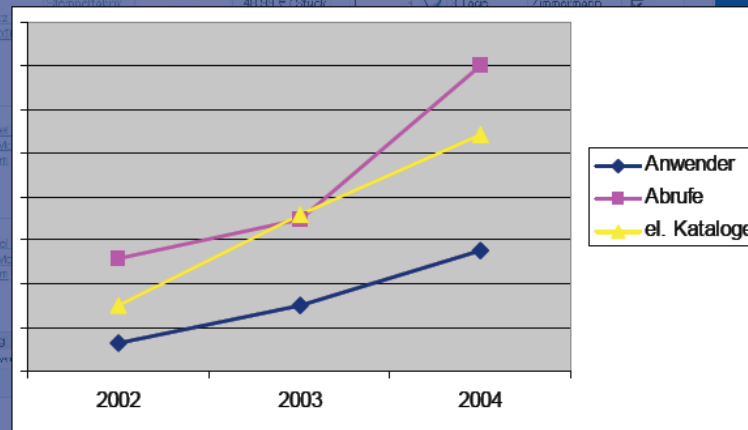

Vorteile aus dem Projekt cWay

DAIMLERCHRYSLER

Vorteile von cWay auf Seiten des Lieferanten sowie DaimlerChrysler

Vorteile Lieferant

Sichere und schnelle Zahlungsabwicklung durch

- Reduzierung der Preisclearing-Fälle
- Gutschriftverfahren

Erhöhung der Datenqualität im Abruf, da die Kataloginformationen des Lieferanten genutzt werden können (Werksprojektentscheidung)

Höhere Sicherheit und Klarheit bei der Zuordnung und Belieferung der durch DC bestellten Artikel (Reduzierung Falschlieferungen)

Reduzierung der Beschaffungswege, da mittelfristig eine zentrale Schnittstelle für alle NPM-Abrufe angestrebt wird

Harmonisierung von Mengeneinheiten in der Lagerbeschaffung

Wegfall der Bearbeitung von z.T. werksbezogenen Sachnummernabschlüssen

Stärkung der Wettbewerbsposition

Vorteile DaimlerChrysler

Elektronische Kataloge sind Preisbasis für das Massengeschäft der Lagerbeschaffung von Nicht-Produktionsmaterial

Reduzierung des Klärungsaufwands in der Rechnungsprüfung durch richtige, rechtzeitige und automatische Bepreisung von Lagerabrufen

Konsequente Nutzung der Einkaufsabschlüsse im Lagerbeschaffungsprozess und aktivere Sortimentsgestaltung

Höhere Qualität in der Bestandsrechnung

Unternehmensweite Transparenz über die Lagerbeschaffungsvorgänge

Aufwandsreduzierung im Einkauf durch

- Reduzierung von Einzelvorgängen und
- Entfall von Sachnummernabschlüssen

Transparenz über redundante DC-Sachstämme
=> Bündelung & Standardisierung

BME-Katalog erstellen

Pfade | Katalog | Preise | Lieferant | Käufer | Regeln | Ersetzen | Einstellungen | Zusatzeinstellungen

Verfügbare Profile

- BMECat
- BMECat (b01)
- BMECat (b)
- BMECat (a01_01)
- BMECat (b03)
- BMECat (c01_01)
- BMECat (c02_19)
- BMECat (c02_20)
- BMECat (c03_19)
- BMECat (e01_01)
- BMECat (a02)
- BMECat (e01_02)
- BMECat (e01_09)
- BMECat (d01)
- BMECat (d01_10)
- BMECat (d02)
- BMECat (d04)
- BMECat (normalien)
- BMECat (f)
- BMECat (a01)
- BMECat (c)
- BMECat (d)
- BMECat (e)
- BMECat (n)

Definition der Regeln

+/-	Beschreibung	Zustand	Max. Länge	Gewählte Quelle
	<HEADER>	muss		
+	<T_NEW_CATALOG>	kann		
+	<CLASSIFICATION_SYSTEM>	darf nicht		
+	<CATALOG_GROUP_SYSTEM>	kann		
+	<ARTICLE>	muss		
	<SUPPLIER_AID>	muss	32	Normbezeichnung
+	<ARTICLE_DETAILS>	muss		
	<DESCRIPTION_SHORT>	muss	80	
	<DESCRIPTION_LONG>	kann	64000	
	<MANUFACTURER_TYPE_DESCR>	kann	50	
	<EAN>	kann	14	
	<SUPPLIER_ALT_AID>	kann	50	
	<BUYER_AID>	kann	50	

Inhalt

Quelle: Template:

Schlüssel (KEY):

EXTRACT

+ Gives access to many e-procurement platforms and consequently to new prospect customers

Marketing Power/ Market Position

Project Management & Single Source

Smart Parts & Processes

Printed Catalog

Assistant & Configurator

BMECAT & WebEDI

Paradigm Shifts

Geometrical Search

Collaboration



Marketing Power/ Market Position

Project Management & Single Source

Smart Parts & Processes

Printed Catalog

Assistant & Configurator

BMECAT & WebEDI

Paradigm Shifts

Geometrical Search

Collaboration

Welches Teil ist geometrisch
NICHT ähnlich?



Typically Problem Of Many Customers

Do supplier XXX have such types of plates ?
It would causes me 10 minutes to find them !

**Let me do it myself
by changing an
existing !!!**

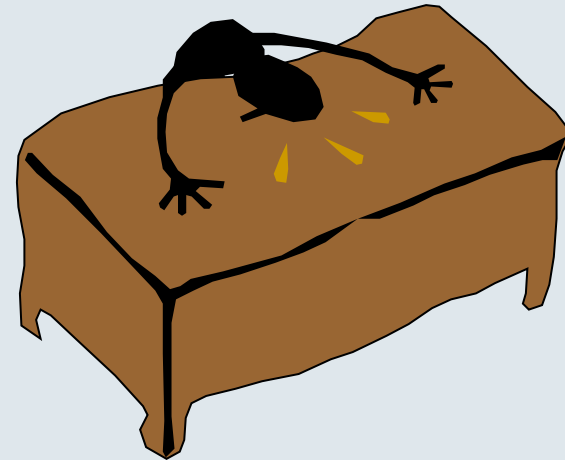
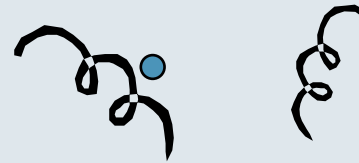

EXTRACT

- Frequent problem:
Customers don't find things
and decide otherwise

*** IDEA ***

Yeasterday I red an article
about MISUMIs leading
products and that they offer
A new plattform whether I
upload my part and get
proposals.

*** Lets Try It ***

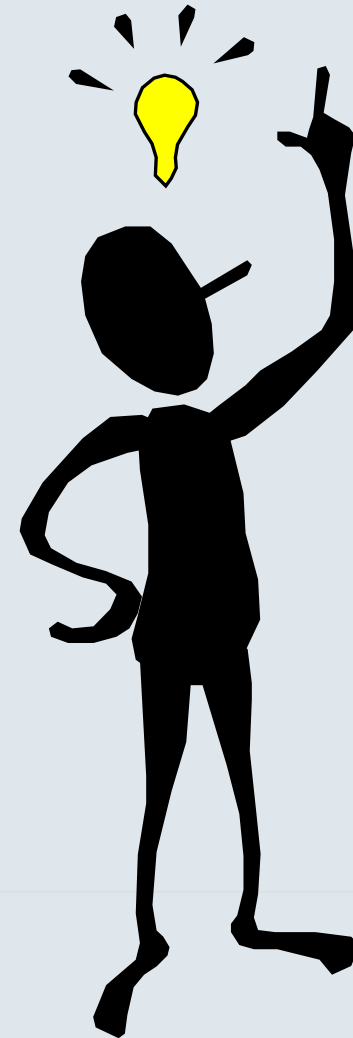
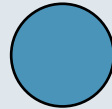

I red I only have to upload a parts and 1-2 sec I get an answer.

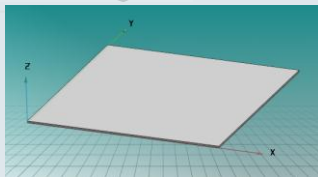
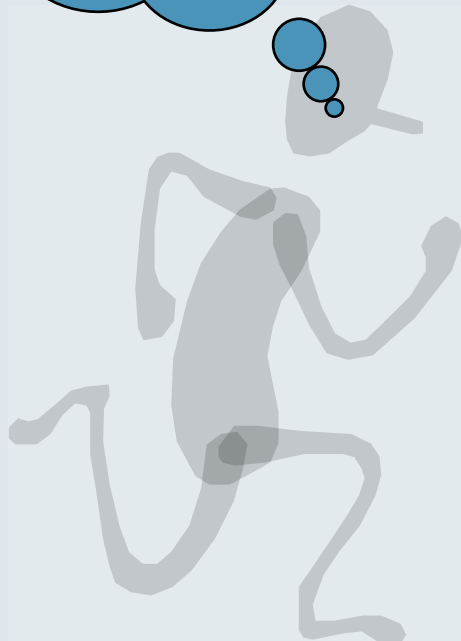

MISUMI USA, Inc.

Misumi - Metric/Resin Plates

<input checked="" type="checkbox"/>	1. CAD-Format/Setup
<input type="checkbox"/>	2. Teile auswählen
<input type="checkbox"/>	3. kostenloser CAD-D
<input type="checkbox"/>	4. Absenden

	BLA, BLBA Bakelite Plates - Paper Base 28.11.2005
	BLSA Bakelite Plates - Cloth Base 23.11.2005
	EPXA Epoxy Glass Plates 23.11.2005
	HIPA Insulating Plates, Standard Grade 25.11.2005
	HIPHA Insulating Plates, Heat-Resistant Grade 25.11.2005
	HIPYA Insulating Plates, High Strength Grade 25.11.2005
	HIPLA Insulating Plates, High Temperature Durability Grade 23.11.2005
	HIPIA Insulating Plates - High Temperature Insulating Grade 21.11.2006
	PAA, PABA, PABAH Polyacetal Plates 27.10.2006
	MCA, MCAW, MCAS, MCCA, MCDA MC Nylon Plates 01.12.2005

http://cprog028:8080/GeomSearchBenchmark/frameset/mainFrames.jsp - Microsoft Internet Explorer

DATEI Bearbeiten Ansicht Favoriten Extras ?

Zurück Suchen Favoriten Medien

Adresse http://cprog028:8080/GeomSearchBenchmark/frameset/mainFrames.jsp

PARTSOLUTIONS GEOMSEARCH

POWERED BY CADENAS

Suche

Durchsuchen



STL Datei Upload

Suchen



POWERED BY CADENAS | PART

Suchergebnisse

#	Part	OBJEKT	...
	Name C000_2_F21_Q73_02.prj ERP_PDM_NUMBER C000-2-F21-Q73-02	95%	
	Name L534_76327_200_00.prj ERP_PDM_NUMBER L534-76327-200-00	95%	
	Name M_DA_N125_5_5_5.prj ERP_PDM_NUMBER M-DA-N125-5-5-5	93%	94%

PARTcommunity

Lokales Intranet

EXTRACT

+ Helps customer easier to Find Misumi product

+ Using more Misumi products instead of self-made Components or other suppliers

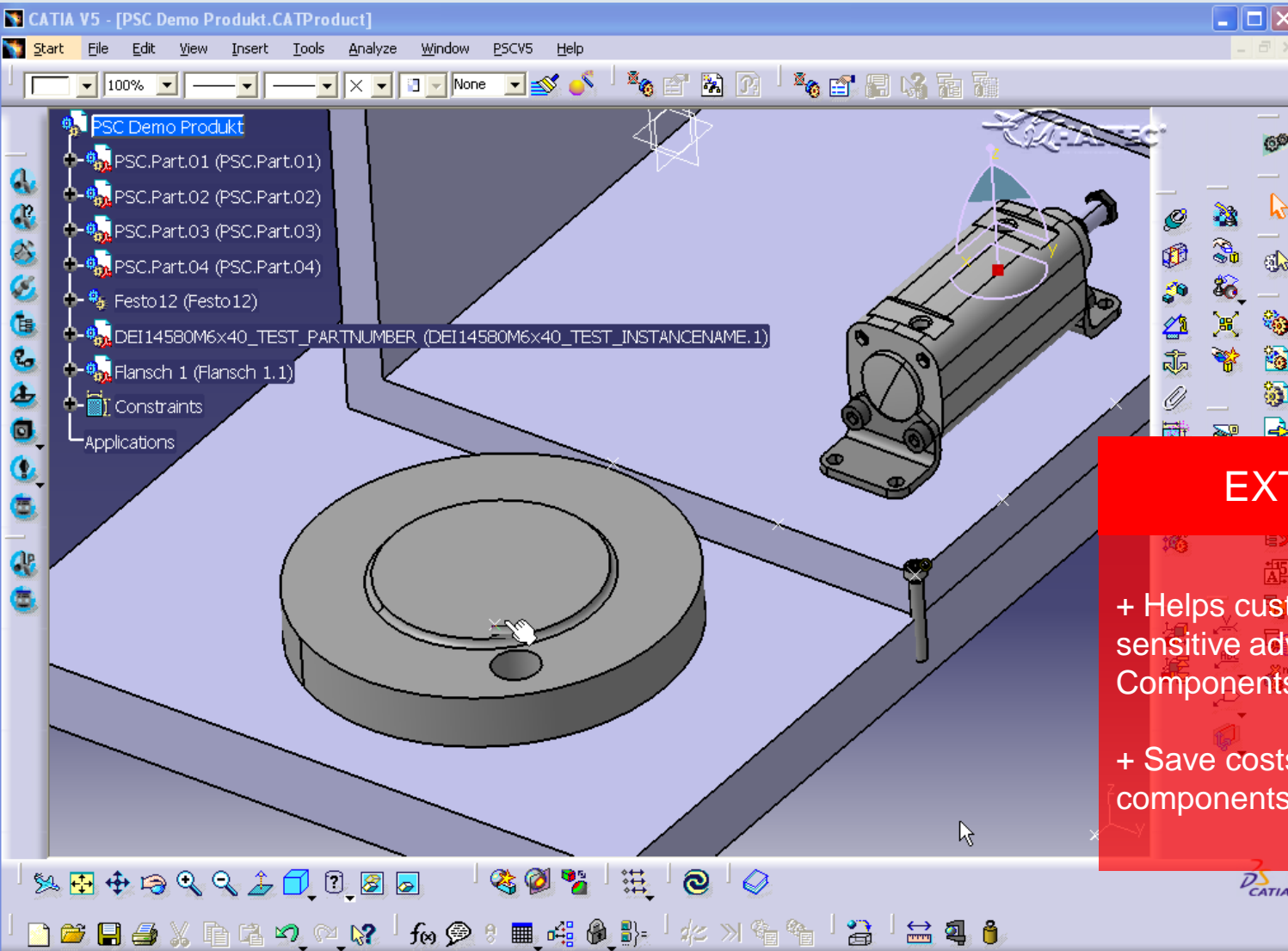

EXTRACT

+ Helps customer by context sensitive advices of similar Components in real-time

+ Save costs by reusing components

Marketing Power/ Market Position

Project Management & Single Source

Smart Parts & Processes

Printed Catalog

Assistant & Configurator

BMECAT & WebEDI

Paradigm Shifts

Geometrical Search

Collaboration



I would have a question to products of XXX ?
Whether they would fit instead of a self-made part ?
BUT: Til the sales representiv could visit me and overview the requirement, it would cause 4 hours of my time.
Lets Do-It-Yourselfe !!!

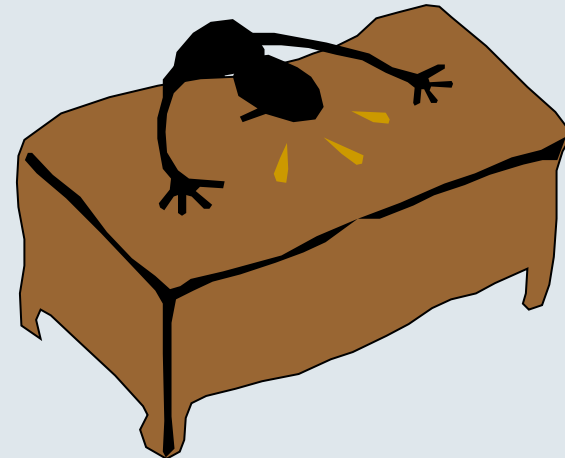
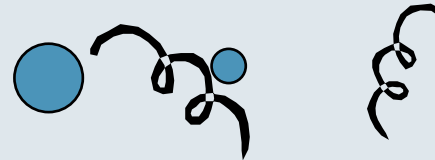

EXTRACT

- Also It would cause XXX
4 hours of worthless
travelling time which makes
product more expensive

*** IDEA ***

Yeasterday I red an article
about MISUMIs leading
products and they promised
me answers inside 30
minutes.

*** Lets Try It ***

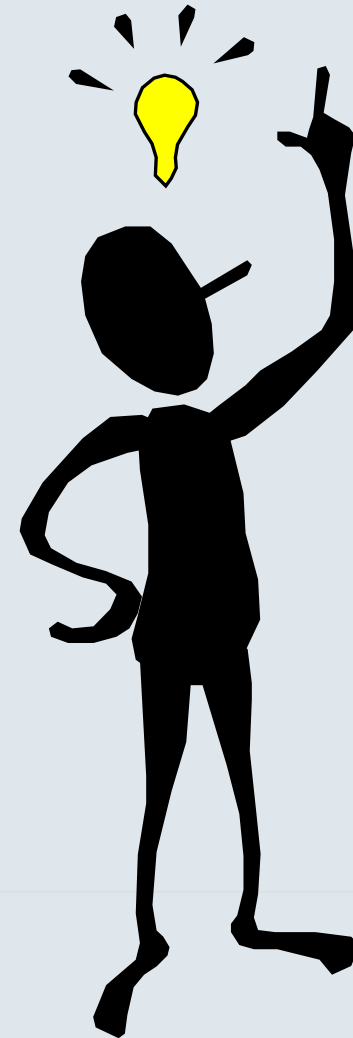
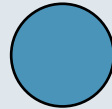

I red I only have to press the button with the red phone and give my contact data.

The screenshot shows a web browser window displaying the CADENAS PART server interface. The browser address bar shows "LEO D-E Ergebnisse für 'Herausheben'". The page title is "PARTserver - Norm- und Zukaufteile / P...". The interface includes a "MISUMI USA, Inc." header, a "SETUP" section with checkboxes for "1. CAD-Format/Setup wählen", "2. Teile auswählen", "3. kostenloser CAD-Datenversand", and "4. Absenden". There are icons for "Teilebaum anzeigen", "Zum kostenlosen CAD-Datenversand", and "Hilfe anzeigen". The main content area features a search bar and a list of MISUMI products, including various linear bushings and stoppers. A red rotary phone icon is prominently displayed on the right side of the interface, with a large blue arrow pointing from it towards the MISUMI building image in the bottom right corner.





Brand New Solutions By CADENAS: Collaboration Platform

EXTRACT

- + Much faster answers for your customerbase
- + Lower costs by Web support
- + Get more information per customer with same team size
- + Offer a new paradigm shift and move customers from their existing suppliers

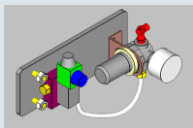
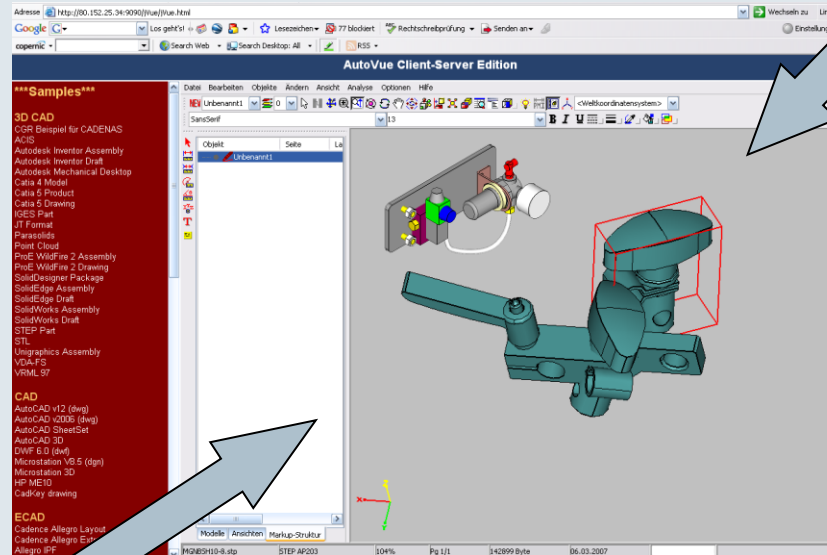
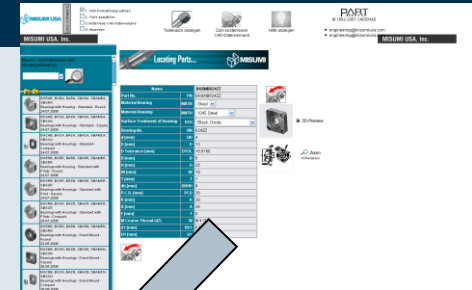
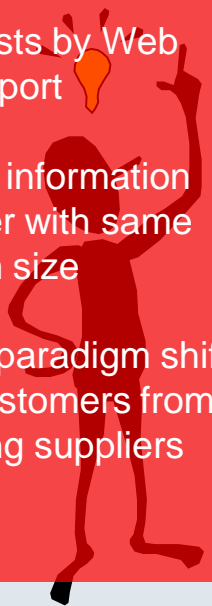

Questions ?

Feedback?

**Thank You For Your
Attention !**