

## SN1830D-HSS- / SN1830D-ASP-

	d1	L1	d2	h	r	d1	L1	d2	h	r
* nicht in Material D-ASP lieferbar can not be delivered in material D-ASP ne peut pas être livré en matériel D-ASP	8,5	71 / 80 /	11,0	3,17	1,0 <sup>+0,5</sup>	14,5*	71 / 80 /	17,0	3,67	1,5 <sup>+0,5</sup>
** in Material D-ASP nur in der Länge 100 lieferbar can only be delivered in material D-ASP in length 100 peut seulement être livré en matériel D-ASP en longueur 100	9,0	100	11,0	2,73		15,0	100	17,0	3,23	
	9,5***		12,0	3,17		15,5*		18,0	3,67	
	10,0		12,0	2,73		16,0		18,0	3,23	
	10,5**		13,0	3,17		16,5		19,0	3,67	
	11,0		13,0	2,73		17,0		19,0	3,23	
	11,5*		14,0	3,17		17,5		20,0	3,67	
*** in Material D-ASP nur in den Längen 71 + 100 lieferbar can only be delivered in material D-ASP in lengths 71 + 100 peut seulement être livré en matériel D-ASP en longueurs 71 + 100	12,0		14,0	2,73		18,0		20,0	3,23	
	12,5**		15,0	3,17		18,5		21,0	3,67	
	13,0		15,0	2,73		19,0		21,0	3,23	
	13,5*		16,0	3,67	1,5 <sup>+0,5</sup>	19,5		22,0	3,67	
	14,0		16,0	3,23		20,0		22,0	3,23	

4

### Schneidstempel

### Cutting punches

### Poinçons de découpe

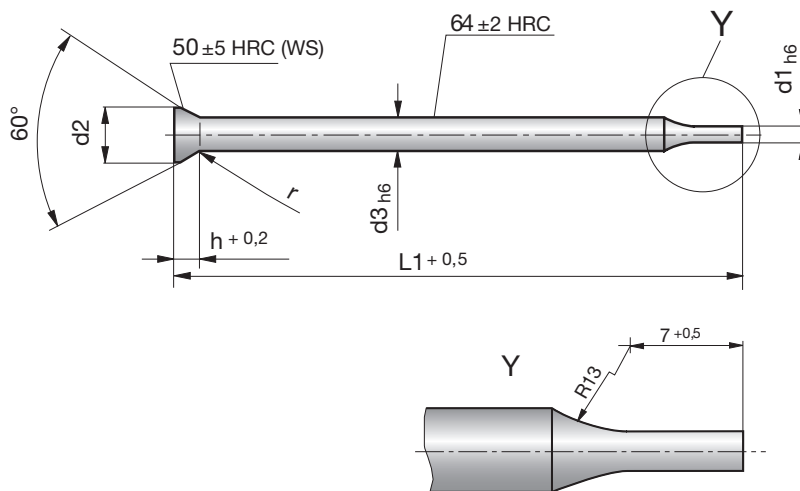

**SN1830C-HSS-  
SN1830C-ASP-**

Mat.: HSS (1.3343)/DIN 9861 C

Mat.: ASP 23/DIN 9861 C

SN1830C-HSS-d1-L1  
SN1830C-ASP-d1-L1

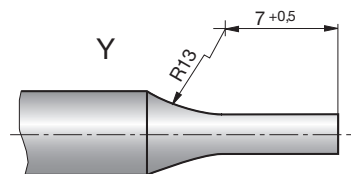

X\* — Stufung in mm  
— graduation in mm  
— progression en mm

d1	L1	d2	d3	X* (d1)	h	r
0,5 - 0,9	71 / 80	3,0	2	0,1	1,37	0,4 <sup>+0,3</sup>
1,0 - 1,5		3,0	2		1,37	0,4 <sup>+0,3</sup>
1,6 - 2,2		4,5	3		1,80	0,6 <sup>+0,4</sup>
2,3 - 2,9		4,5	3		1,80	0,6 <sup>+0,4</sup>