

Flange Coupling

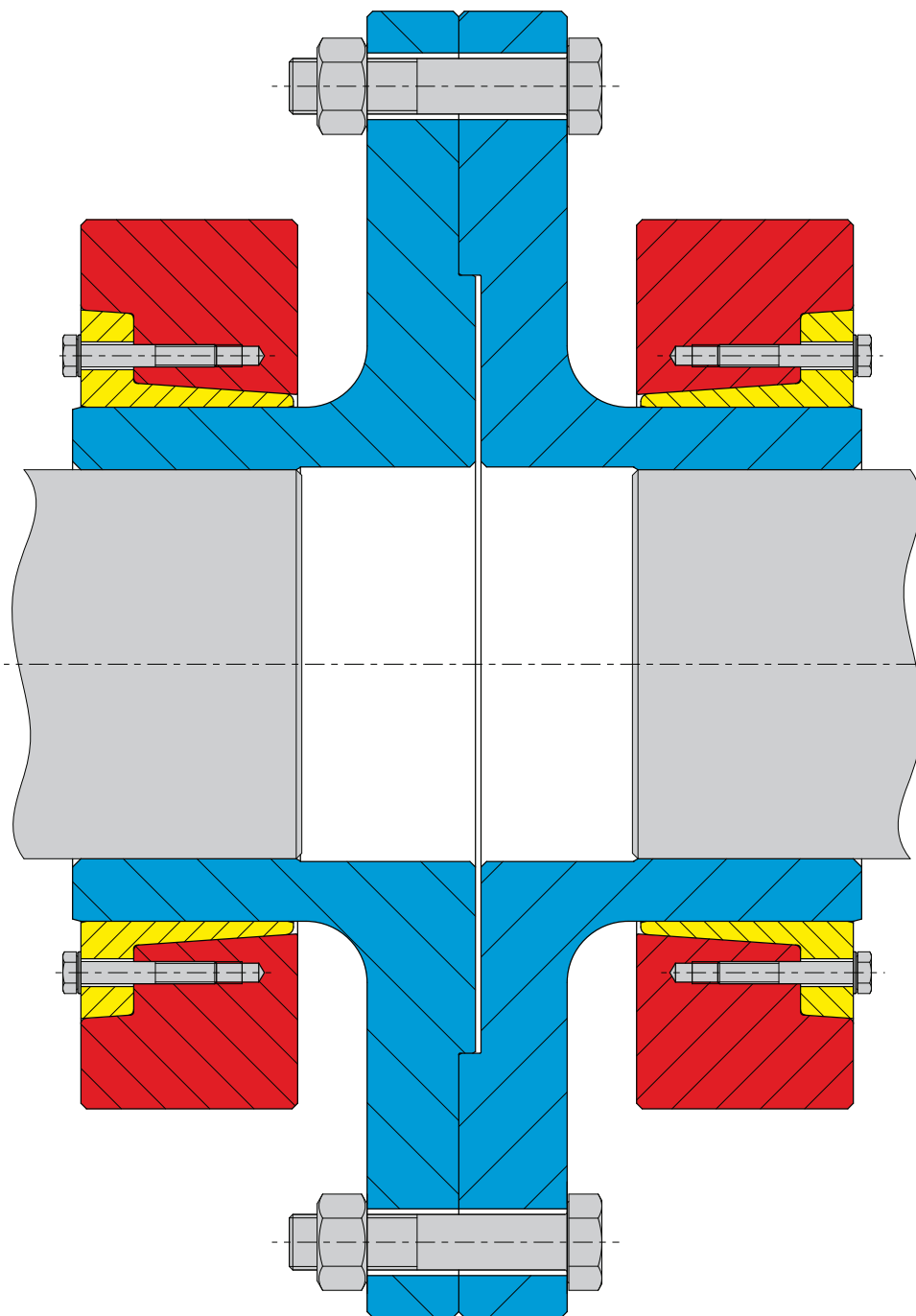

Flanges

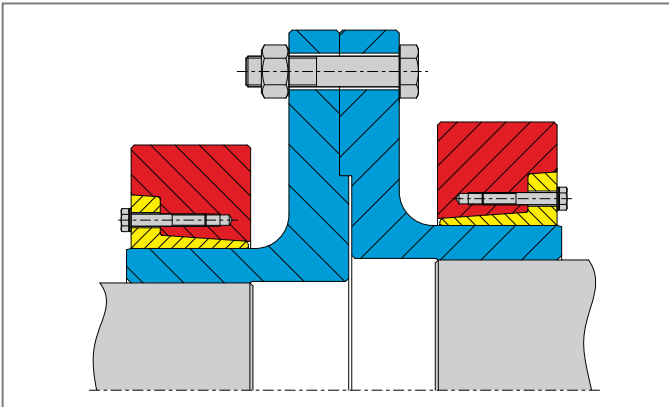

Complete flange coupling comprising two halves for connecting shafts of similar or different shaft diameters.

Mechanical or hydraulic locking.

Also with marine classification inspection.

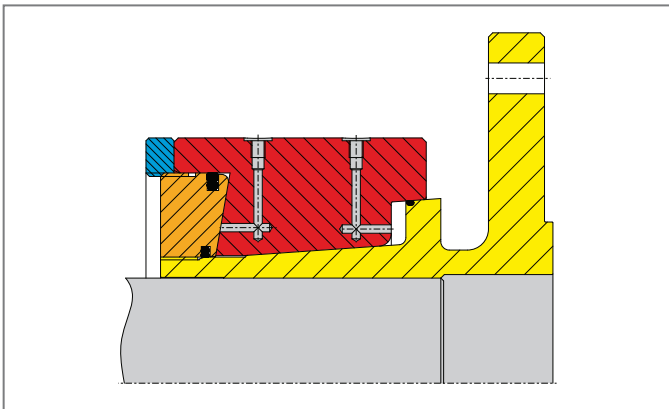

Flange coupling with internal or external spigot locations for connecting flange.

Mechanical or hydraulic locking.

Also with marine classification inspection.

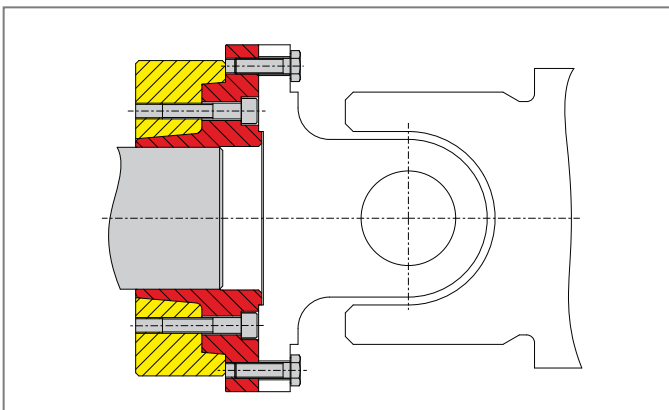

Universal joint connection (cardan shaft coupling).

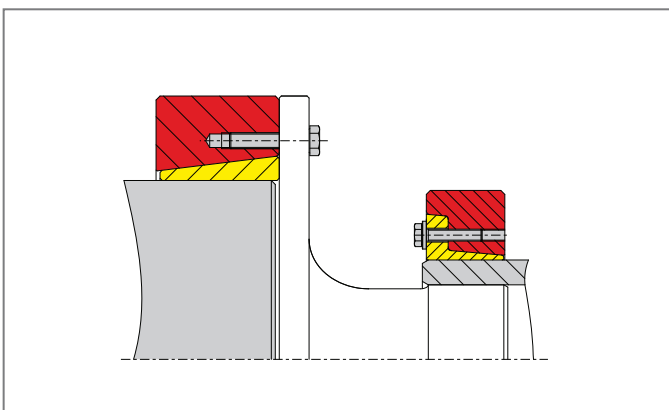

Special flanges for optimal solutions.

Flange Coupling FKH

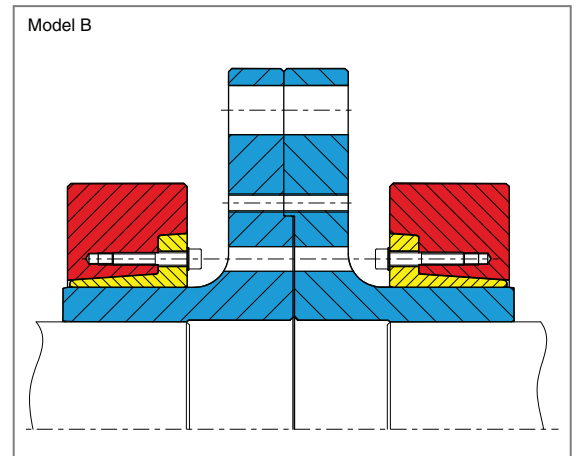
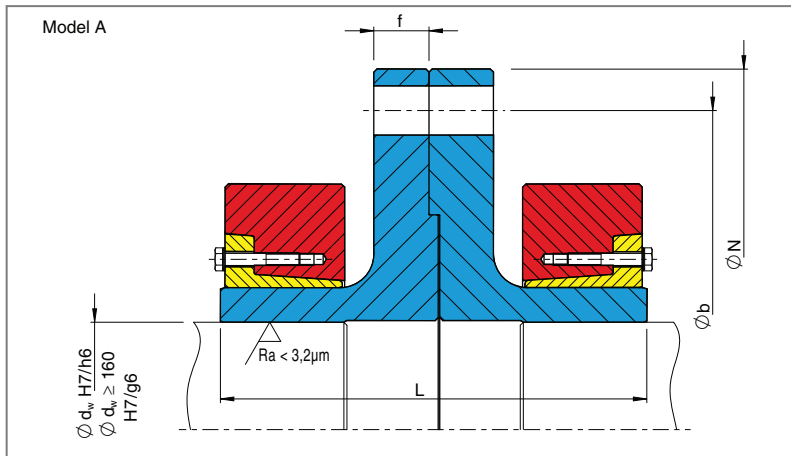

Code: M_t maximum transmissible torque
 M_a required tightening torque of the tightening bolts (see also "Mounting and Removal Instructions")
 $M_a FI$ required tightening torque of the flange bolts

Type	d_w mm	M_t kNm	Shrink Disc	M_a Nm	B^{**}	N mm	b mm	L mm	f mm	Flange bolts*	$M_a FI$ Nm	kg
FKH 240 - 80	70	6	HSD 100 - 22	58	M10	240	206	136	18	6 x M16	210	27
	75	7										
	84	10										
FKH 300 - 90	85	12	HSD 125 - 22	100	M12	300	260	160	20	6 x M20	420	47
	95	16										
	100	19										
FKH 340 - 100	95	17	HSD 140 - 22	160	M14	340	280	190	24	5 x M24	720	61
	100	20										
	115	28										
FKH 370 - 110	115	30	HSD 155 - 22	160	M14	370	310	210	24	8 x M24	720	78
	120	33										
	125	36										
FKH 400 - 120	120	37	HSD 165 - 22	240	M16	400	350	228	30	8 x M24	720	110
	125	41										
	135	50										
FKH 400 - 130	130	45	HSD 175 - 22	240	M16	400	350	228	30	8 x M24	720	112
	135	49										
	145	58										
FKH 470 - 140	140	64	HSD 185 - 22	240	M16	470	416	278	36	10 x M30	1450	173
	145	70										
	150	76										
FKH 470 - 150	150	80	HSD 200 - 22	240	M16	470	416	278	36	10 x M30	1450	182
	155	87										
	160	93										
	170	119										
FKH 520 - 160	160	103	HSD 220 - 22	470	M20	520	456	300	36	12 x M30	1450	245
	165	110										
	170	119										
FKH 560 - 180	170	122	HSD 240 - 22	470	M20	560	496	322	36	16 x M30	1450	302
	180	140										
	190	159										

*Grade 10.9 **Tightening bolts for Model A: DIN EN ISO 4014/4017, Model B: DIN EN ISO 4762
 When ordering please state: e.g. FKH340 - 100x100 (Type x $\varnothing d_w$) Quantity & size of flange bolts

Type	d _w mm	M _t kNm	Shrink Disc	M _a Nm	B**	N mm	b mm	L mm	f mm	Flange bolts*	M _a Fl Nm	kg
FKH 560 - 200	190	163	HSD 260 - 22	470	M20	560	496	322	36	16 x M30	1450	334
	200	184										
	210	207										
FKH 590 - 220	210	215	HSD 280 - 22	470	M20	590	526	392	40	18 x M30	1450	420
	220	240										
	230	267										
FKH 630 - 240	220	271	HSD 300 - 22	820	M24	630	550	408	40	18 x M30	1450	494
	230	300										
	240	331										
FKH 630 - 250	240	301	HSD 320 - 22	820	M24	630	550	408	40	18 x M30	1450	534
	250	332										
	260	364										
FKH 710 - 260	250	390	HSD 340 - 22	820	M24	710	656	450	40	24 x M30	1450	717
	260	427										
	270	466										
FKH 710 - 280	270	496	HSD 360 - 22	820	M24	710	656	450	40	24 x M30	1450	754
	280	539										
	290	584										
FKH 800 - 300	290	640	HSD 390 - 22	1210	M27	800	736	500	50	28 x M30	1450	1006
	300	691										
	320	800										
FKH 800 - 330	320	742	HSD 420 - 22	1210	M27	800	736	540	50	28 x M30	1450	1158
	330	797										
	350	911										

Further sizes on request.

Technical changes to be reserved without notice.

*Grade 10.9 **Tightening bolts for Model A: DIN EN ISO 4014/4017

Model B: DIN EN ISO 4762

When ordering please state: e. g. FKH 710 - 260x270 (Type x Ø d_w)

Quantity & size of flange bolts

Flange Coupling FKHA

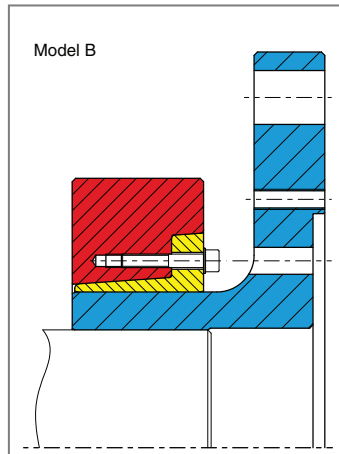
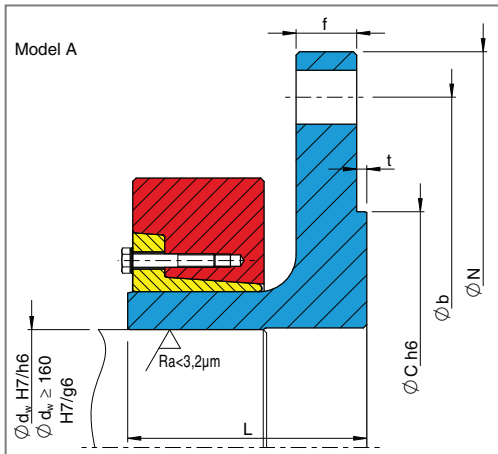

Code:

- M_t maximum transmissible torque
- M_a required tightening torque of the tightening bolts (see also "Mounting and Removal Instructions")
- M_a FI required tightening torque of the flange bolts

Dimensions N, b, c, t plus quantity and size of flange bolts depend on the counterflange and can be changed if necessary. Flanges can also be supplied counterbored for internal spigot location.

Type	d_w mm	M_t kNm	Shrink Disc	M_a Nm	N mm	b mm	c mm	L mm	f mm	t mm	Flange bolts*	M_a FI Nm	kg
FKHA 340 - 100	95	17	HSD 140 - 22	160	340	280	200	98	24	6	5 x M24	720	28
	100	19											
	110	24											
FKHA 400 - 120	120	35	HSD 165 - 22	240	400	350	250	114	30	6	8 x M24	720	50
	125	38											
	130	42											
FKHA 400 - 130	130	42	HSD 175 - 22	240	400	350	250	114	30	6	8 x M24	720	51
	135	46											
	140	50											
FKHA 470 - 140	140	61	HSD 185 - 22	240	470	416	280	139	36	6	10 x M30	1450	80
	145	67											
	150	72											
FKHA 470 - 150	150	78	HSD 200 - 22	240	470	416	280	142	36	6	10 x M30	1450	84
	155	84											
	160	90											
FKHA 520 - 160	160	101	HSD 220 - 22	470	520	456	320	150	36	8	12 x M30	1450	112
	165	109											
	170	117											
FKHA 560 - 180	170	122	HSD 240 - 22	470	560	496	360	161	36	8	16 x M30	1450	137
	180	140											
	190	159											
FKHA 560 - 200	190	163	HSD 260 - 22	470	560	496	360	165	36	8	16 x M30	1450	152
	200	184											
	210	207											
FKHA 590 - 220	210	215	HSD 280 - 22	470	590	526	380	200	40	8	18 x M30	1450	184
	220	240											
	230	267											
FKHA 630 - 250	240	301	HSD 320 - 22	820	630	550	430	204	40	8	18 x M30	1450	239
	250	332											
	260	364											
FKHA 710 - 280	270	496	HSD 360 - 22	820	710	656	480	229	40	8	24 x M30	1450	338
	280	539											
	290	584											
FKHA 800 - 300	290	640	HSD 390 - 22	1210	800	736	520	250	50	8	28 x M30	1450	451
	300	691											
	310	744											
FKHA 800 - 330	320	742	HSD 420 - 22	1210	800	736		250	50		28 x M30	1450	513
	330	797											
	340	853											

Further sizes on request. Technical changes to be reserved without notice.

*Grade 10.9 **Tightening bolts for Model A: DIN EN ISO 4014/4017, Model B: DIN EN ISO 4762

When ordering please state : e. g. FKHA 590-220x220 (Type x $\varnothing d_w$) Dimensions N,b,c,t Quantity & size of flange bolts

Mounting- und Removal Instructions for Flange Coupling FKH

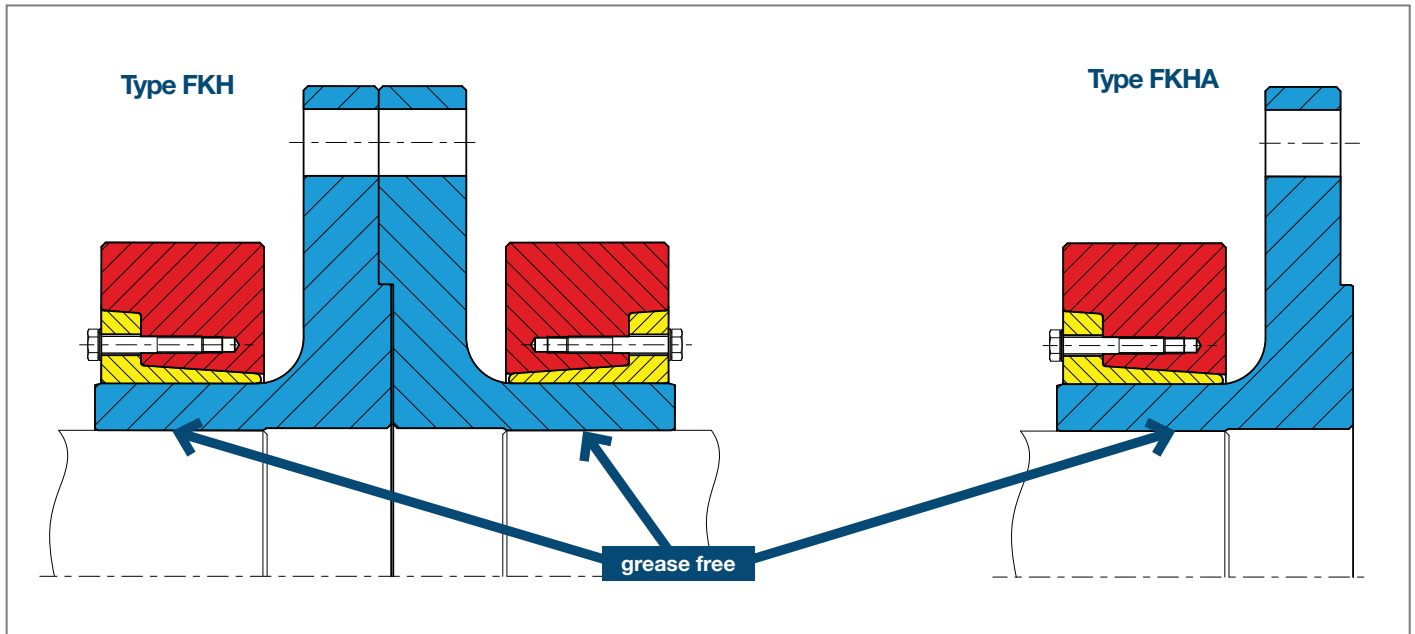

Mounting

The STÜWE® flange couplings type and FKHA are supplied ready to be mounted. Therefore they should not be dismantled prior to employing the unit for the first time.

1. Degrease the flange bore and shaft. Safe torque transmission substantially depends on this procedure. Dirty solvents or cleaning cloths are unsuitable for degreasing.
2. Push the flange onto the shaft.
3. Tighten four bolts evenly distributed over the circumference by reduced torque (approx. 50 to 70 % of maximum tightening torque) on each shrink disc.
4. Afterwards tighten all tightening bolts uniformly, one by one, over several revolutions. When tighten the bolts it will initially tilt with an in and out radial motion until the fit clearances are bridged.

Thereafter a true seat between bore and shaft is achieved and any tilting eliminated.

5. All bolts are tightening until the outer ring and inner ring are flush. This indicates that the full transmissible torque is achieved.

Check each tightening bolt twice for the required tightening torque.

Dismounting

This is similar to mounting.

1. Loosen all locking bolts uniformly one by one, initially not more than a quarter turn per bolt, until it is observed that the outer ring has released from the inner ring.



Under no circumstances should the locking bolts be completely removed as this could be dangerous and result in injury.

2. Should the outer ring, when losing the bolts, not slide automatically from the inner ring, this can be assisted by removing those locking bolts adjacent to the tapped holes provided for jacking purposes and screwing them into these tapped holes. The jacking procedure must continue until release of the outer ring is achieved.
3. Dismount shaft or draw off flange. Remove rust which may have formed on the shaft in front of the flange.

Cleaning and greasing

Dismantled shrink discs do not have to be dismantled and re-lubricated before remounting.

The shrink disc has to be cleaned and re-lubricated only if employed in dirty environment.

Use a solid containing lubricant with a high content of MoS₂ and a coefficient of friction of $\mu = 0,04$ for the conical surfaces. Usually a combination of bonded coating and paste is chosen.

Examples for Lubricant

Lubricant	Source
Molykote D 321 R (bonded coating)	Dow Corning
Aema-Sol MO 84-K (bonding coating)	A.C. Matthes
Molykote G Rapid + (paste)	Dow Corning
Aema-Sol M 19 P (paste)	A.C. Matthes

The bolts have to be renewed if possible. The bolts are lubricated with commercially available bolt lubricants ($\mu = 0,1$).

Flange Coupling FK HYD

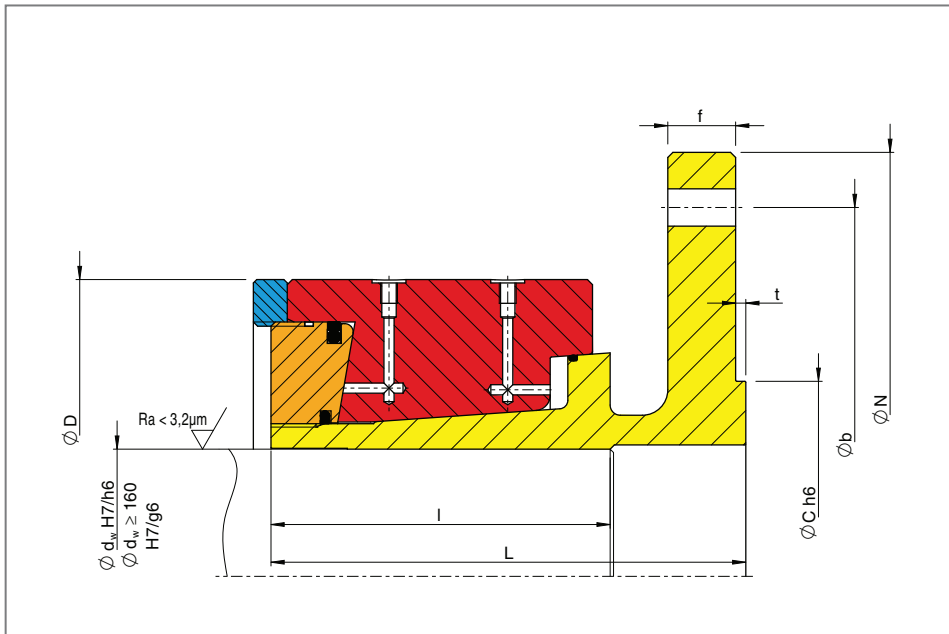

Code:

M_t = maximum transmissible torque
torque

max. hyd. press =
maximum hydraulic clamping pressure

Dimensions N, b, c, t plus quantity and size of flange bolts depend on the counterflange and can be changed if necessary.

Flanges can also be supplied counterbored for internal spigot location.

Type	d_w mm	M_t kNm	max. hyd. press bar	N mm	D mm	L mm	l mm	f mm	kg
FK HYD 400 - 120	120	40	450	400	300	150	90	30	69
	130	48							
	140	57							
FK HYD 470 - 160	150	87	450	470	340	185	117	36	111
	160	101							
	170	115							
FK HYD 520 - 180	170	115	450	520	370	185	117	36	131
	180	130							
	190	147							
FK HYD 560 - 200	190	167	450	560	430	210	140	36	189
	200	186							
	210	208							
FK HYD 590 - 220	220	248	450	590	460	240	160	40	234
	230	275							
	240	304							
FK HYD 630 - 240	240	360	450	630	520	260	180	40	325
	250	394							
	260	430							
FK HYD 710 - 260	260	435	450	710	570	310	220	40	455
	270	474							
	280	515							
FK HYD 800 - 300	290	765	450	800	640	320	220	50	611
	300	832							
	310	901							
FK HYD 900 - 340	330	850	450	900	720	360	255	50	857
	340	910							
	360	1030							
FK HYD 1000 - 380	360	1016	450	1000	760	360	255	50	969
	380	1147							
	400	1270							
FK HYD 1100 - 420	400	1915	450	1100	850	420	295	50	1342
	420	2100							
	440	2300							

Further sizes on request. Technical changes to be reserved without notice.
When ordering please state : e. g. FKHYD520 - 180x180 (Type x $\varnothing d_w$) Dimensions N,b,c,t
Quantity & size of flange bolts

Mounting and Removal Instructions for Flange Coupling FKHYD

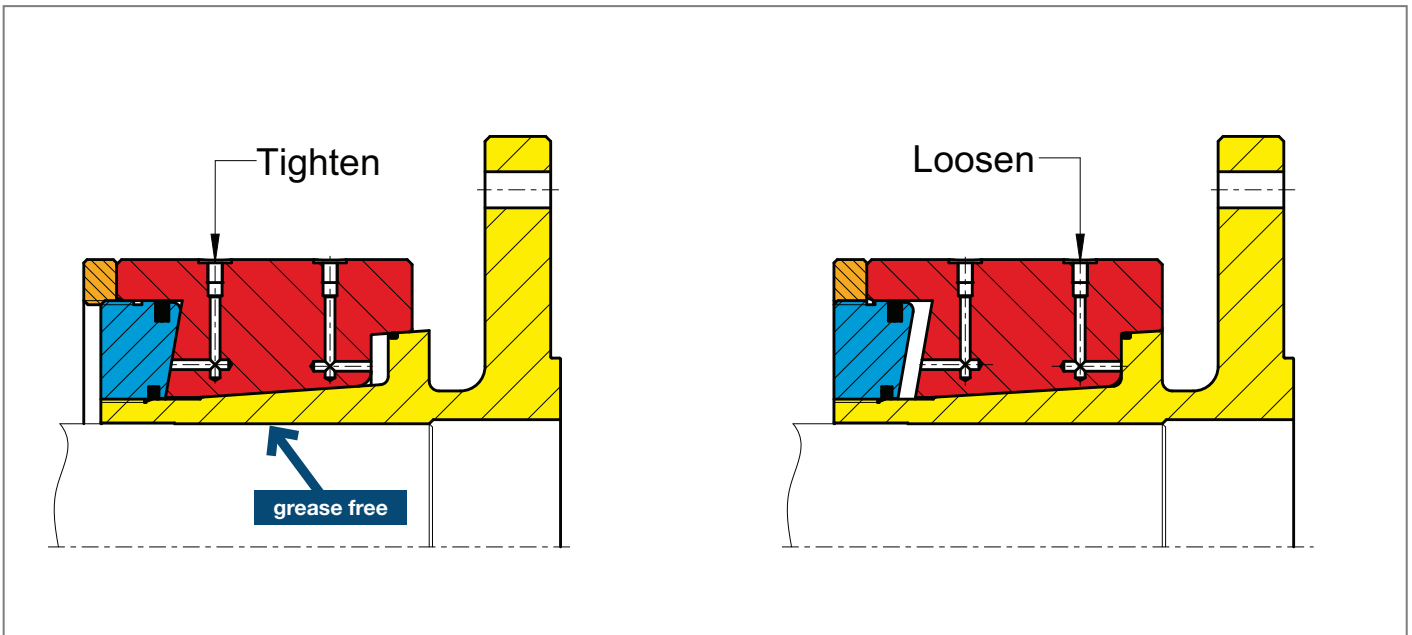

Mounting

The STÜWE® flange couplings type FKHYD are supplied ready to be mounted and with hydraulic oil in the pressure chamber.

1. Shaft and hub must be absolutely free of grease in the fit area. Full torque transmission is absolutely dependant on this measure. Do not use contaminated cleaning solvents and unclean rags.
2. Push the flange on to the shaft.
3. Remove screw plugs from the "Spannen" (Tighten) and "Entspannen" (Loosen) connections. Collect any oil leakage.
4. Connect pressure line to connection marked "Spannen" (Tighten).
5. Tighten the shrink disc by applying hydraulic pressure. The correct tightening force is reached as soon as the end faces of the outer and inner ring are aligned (visually observed to be flush). **Maximum allowable hydraulic pressure is 450 bar!**
6. When pressurising the flange it will initially tilt with an in and out radial motion until the fit clearances are bridged. Thereafter a true seat between bore and shaft is achieved and any tilting eliminated. The correct tightening force requirement is achieved as soon as the outer and inner rings are aligned (visually observed to be flush). The max. allowable hydraulic pressure is stamped on the Flange Coupling.
7. Tighten the counter nut by hand against the outer ring.
8. Release the hydraulic pressure. The safety nut will then be tightly compressed against the outer ring due to the stored energy.
9. Replace the screw plugs to retain the hydraulic oil in flange coupling.

Dismounting

1. Remove screw plugs from the "Spannen" (Tighten) and "Entspannen" (Loosen) connections. Collect any oil leakage.
2. Connect the pressure line to the connection marked "Spannen" (Tighten).
3. Increase the hydraulic pressure until the safety nut can be loosened by hand (max.450 bar!). Continue loosening the safety nut.



Make sure that a minimum of two turns remain connected when loosening the ring nut. Otherwise the nut might fall off! This could be dangerous and result in injury.

4. Release the hydraulic pressure and connect the pump to the "Entspannen" (Loosen) connection.
5. Increasing the oil pressure (max. 450 bar!) will initiate the release of the connection. **As soon as the outer ring starts sliding towards the ring nut reduce the oil pressure immediately to max. 150 bar.** When the outer ring reaches the support ring the oil pressure will automatically increase. **At this point fully release the oil pressure. Make sure the oil pressure does not exceed 180 bar.**
6. The connection is loose now. Collect oil leakage coming out of the "Spannen" (Tighten) connection.
7. Leave all hydraulic oil within the shrink disc and replace the "Spannen" (Tighten) and "Entspannen" (Loosen) screw plugs so that the flange coupling is oil tight.
8. Remove the flange from the shaft. Prior to removal clean off any rust from the shaft in the immediate vicinity of the flange.