

Shaft Coupling Type WK, Type WKL

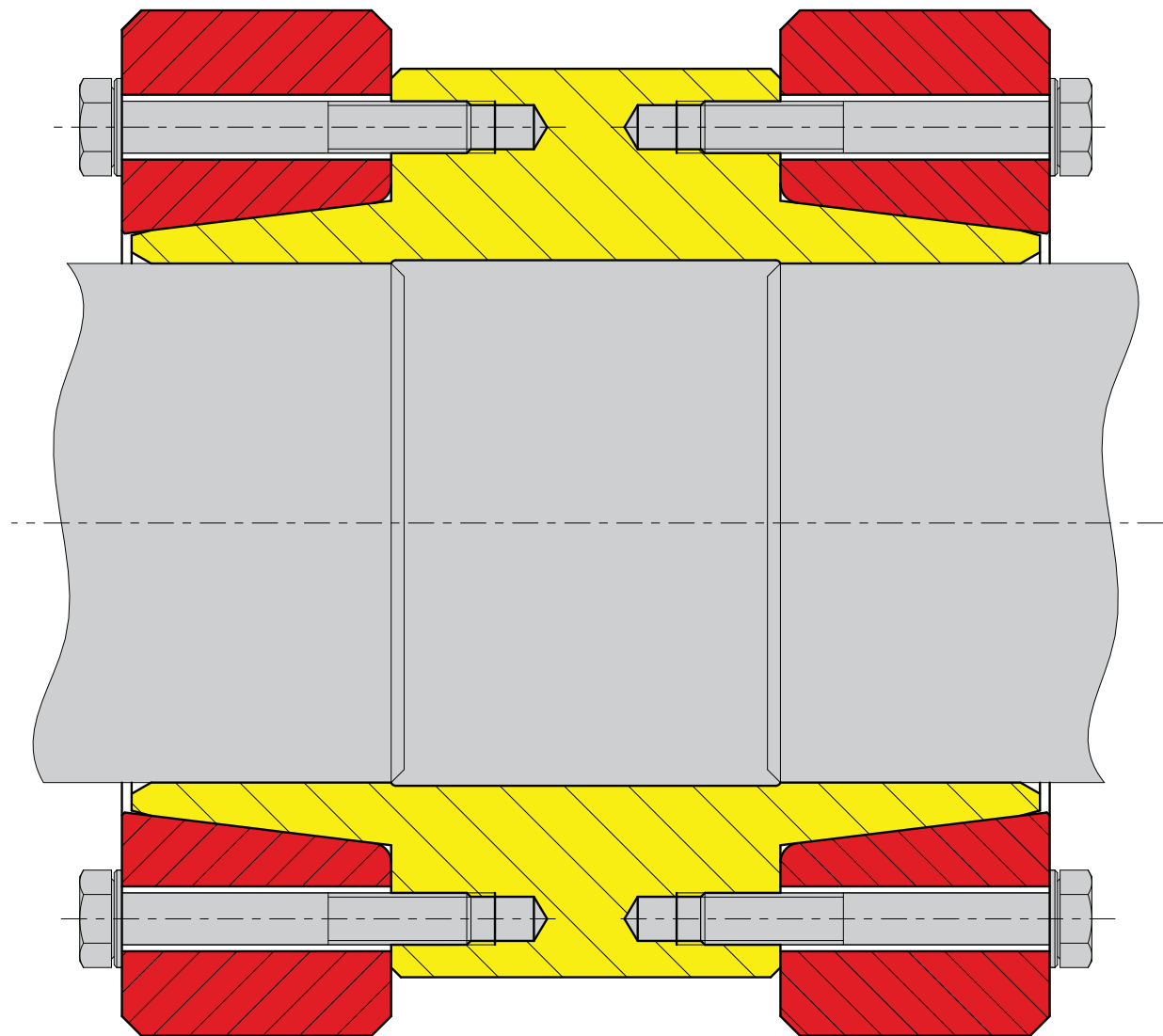

Shaft Coupling Type WK

Series 12

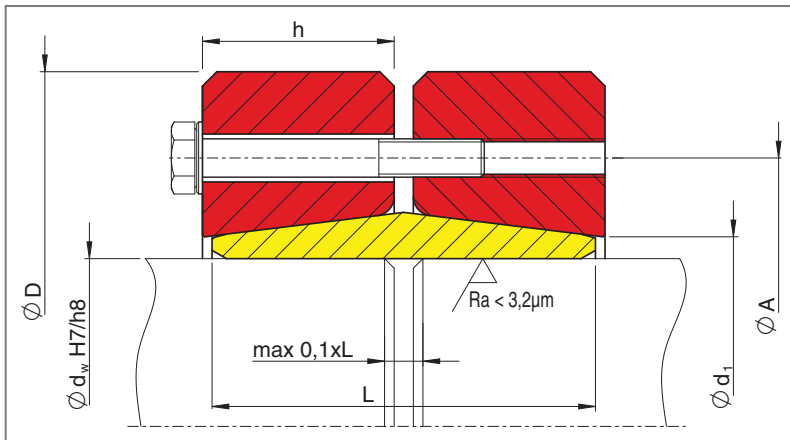

Code:

- M_t maximum transmissible torque of a shrink disc with $P_{ax}=0$
- P_{ax} maximum transmissible axial load of a shrink disc with $M_t=0$
- M_a required tightening torque of the tightening bolts (see also "Mounting and Removal Instructions")

Type	d_w mm	M_t kNm	P_{ax} kN	M_a Nm	B*	D mm	L mm	h mm	A mm	d_1 mm	kg
W K 10 - 12	9	0,04	8	12	M6	39	20	10	25	13	0,2
	10	0,04	9								
	11	0,05	10								
W K 12 - 12	12	0,07	11	12	M6	44	26	13	28	16	0,3
	13	0,08	12								
	14	0,09	13								
W K 15 - 12	15	0,16	21	29	M8	52	30	15	36	21	0,5
	17	0,20	24								
	19	0,26	27								
W K 20 - 12	20	0,29	29	29	M8	60	34	17	42	26	0,7
	22	0,35	32								
	24	0,41	35								
W K 25 - 12	25	0,49	40	29	M8	66	38	19	48	32	0,9
	27	0,58	43								
	29	0,66	46								
W K 30 - 12	30	0,77	51	29	M8	76	42	21	56	38	1,3
	32	0,87	55								
	35	1,05	60								
W K 40 - 12	36	1,3	70	58	M10	96	50	25	70	47	2,5
	40	1,8	92								
	43	2,3	109								
W K 50 - 12	44	2,3	102	100	M12	112	60	30	84	58	4,1
	50	3,4	137								
	54	4,3	161								
W K 60 - 12	55	4,1	150	100	M12	120	70	34	94	66	4,9
	60	5,5	184								
	62	6,1	197								
W K 70 - 12	63	6,2	196	100	M12	148	80	40	112	79	9,1
	70	8,6	245								
	73	9,7	266								
W K 80 - 12	74	10	275	160	M14	170	94	44	130	94	13,1
	80	13	320								
	85	15	358								
W K 90 - 12	86	16	381	240	M16	185	104	50	144	104	17,1
	90	19	417								
	95	22	461								
W K 100 - 12	96	23	483	240	M16	197	114	54	156	114	20,4
	100	26	521								
	106	31	578								
W K 120 - 12	107	35	648	240	M16	230	138	65	174	134	34,3
	120	47	787								
	125	53	841								

*Tightening bolts: standard DINENISO4014/4017 Grade 10.9, alternative DINENISO4762 Grade 10.9
M16 and upwards with washers: DINENISO 7416 When ordering please state : e. g. WK 40 - 12x43 (Type x $\varnothing d_w$)

Series 12

Type	d_w mm	M_t kNm	P_{ax} kN	M_a Nm	B^*	D mm	L mm	h mm	A mm	d_i mm	kg
W K 140 - 12	126	56	881	470	M20	290	160	76	206	160	66,1
	140	74	1052								
	150	88	1178								
W K 160 - 12	150	81	1081	470	M20	320	176	83	234	180	85
	160	96	1202								
	165	104	1264								
W K 180 - 12	165	114	1381	470	M20	340	200	94	276	205	106
	180	143	1594								
	185	154	1665								
W K 200 - 12	185	164	1778	470	M20	370	228	107	290	226	140
	200	201	2011								
	210	228	2169								
W K 220 - 12	210	231	2199	820	M24	405	250	118	320	246	180
	220	260	2362								
	230	291	2527								
W K 240 - 12	230	271	2353	820	M24	430	270	128	340	266	215
	240	302	2513								
	250	334	2675								
W K 260 - 12	240	322	2683	1210	M27	460	290	138	366	288	271
	250	357	2860								
	260	395	3039								
W K 280 - 12	260	424	3265	1210	M27	485	330	166	400	308	355
	270	467	3459								
	280	512	3656								
W K 300 - 12	280	530	3787	1210	M27	520	346	174	420	328	426
	290	579	3990								
	300	629	4195								
W K 320 - 12	300	662	4414	1640	M30	550	376	190	446	348	514
	310	718	4631								
	320	776	4849								
W K 340 - 12	320	806	5038	1640	M30	590	380	194	466	368	607
	330	869	5267								
	340	935	5499								
W K 360 - 12	340	967	5686	2210	M33	650	400	202	500	398	790
	350	1037	5924								
	360	1109	6163								
W K 390 - 12	370	1195	6459	2210	M33	670	440	224	530	428	891
	380	1274	6706								
	390	1356	6954								
W K 420 - 12	400	1637	8187	2210	M33	740	470	238	560	448	1175
	410	1737	8471								
	420	1839	8758								
W K 460 - 12	430	1841	8561	2210	M33	780	500	246	590	498	1291
	450	2050	9112								
	460	2160	9390								
W K 500 - 12	470	2568	10929	2850	M36	860	560	276	648	540	1772
	480	2700	11249								
	500	2974	11895								
W K 550 - 12	510	3014	11820	2850	M36	960	600	296	710	600	2421
	530	3301	12456								
	550	3602	13097								
W K 600 - 12	560	3610	12893	2850	M36	1000	620	310	760	650	2614
	580	3921	13520								
	600	4245	14151								
W K 650 - 12	620	4555	14695	2850	M36	1080	640	320	824	700	3074
	530	4732	15023								
	650	5097	15684								
W K 700 - 12	660	5360	16243	2850	M36	1140	680	340	890	760	3608
	680	5751	16916								
	700	6158	17593								
W K 750 - 12	710	6256	17623	2850	M36	1280	720	360	950	814	5016
	730	6679	18298								
	750	7116	18977								

Further sizes on request. Technical changes to be reserved without notice.

*Tightening bolts: standard DINEN ISO 4014/4017 Grade 10.9, alternative DINEN ISO 4762 Grade 10.9
M16 and upwards with washers: DINEN ISO 7416 When ordering please state : e.g. WK390-12x380 (Type x $\varnothing d_w$)