

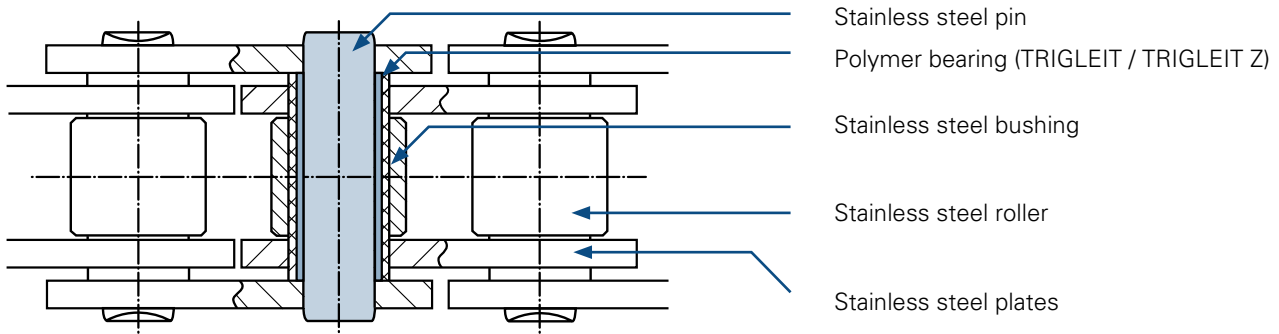

High performance polymer bearing TRIGLEIT



High performance polymer bearing TRIGLEIT Z



MARATHON stainless steel chains

For maximum freedom from maintenance and highest possible lifetime

High performance polymer bearings allow operation of stainless steel chains without relubrication!

Technical features

- Durable and low-friction polymer bearing
- All other chain components made of stainless steel grades
- Maximum chain speed $v = 2,5 \text{ m/s}$
- Working temperature -30°C to $+60^\circ\text{C}$ (TRIGLEIT)
- Working temperature -100°C to $+200^\circ\text{C}$ (TRIGLEIT Z / TRIGLEIT FDA)
- Chain dimensions according to ISO 606; standard stainless steel sprockets can be used
- No relubrication required
- Relubrication with mineral oils possible (no ester oils)
- Can also be supplied with extended pins, straight attachments, bent attachments and in special designs
- Information on chemical resistance on request
- Durable water resistance (TRIGLEIT Z / TRIGLEIT FDA)

Application areas

- Packing industry
- Chemical industry
- Pharmaceutical industry
- Textile industry
- Food industry
- Sanitation industry
- Electrical industry

Results of long-term wear tests

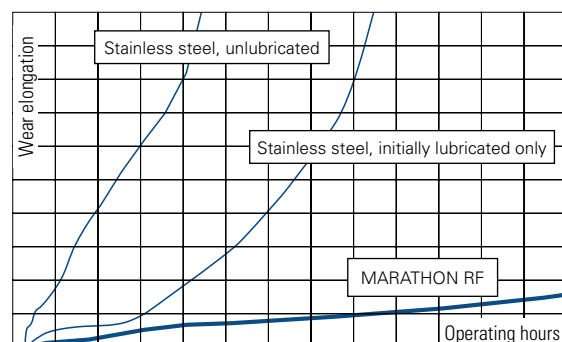



Simplex chains

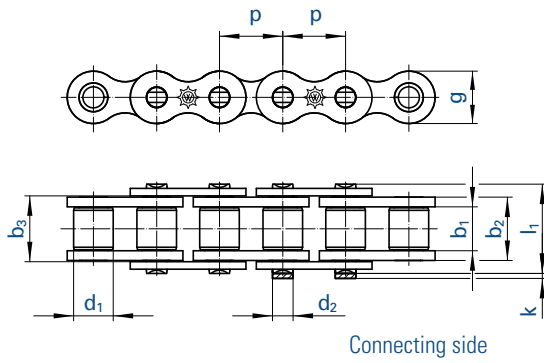

Simplex chains (Type GL)

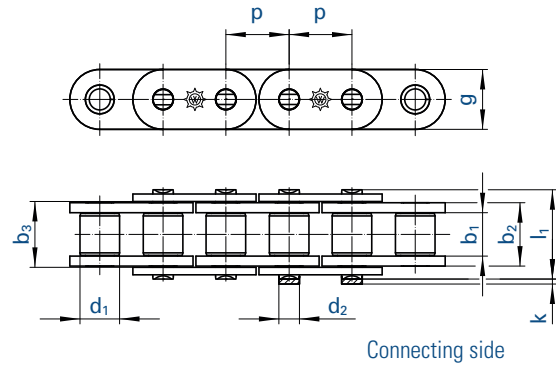

Duplex chains

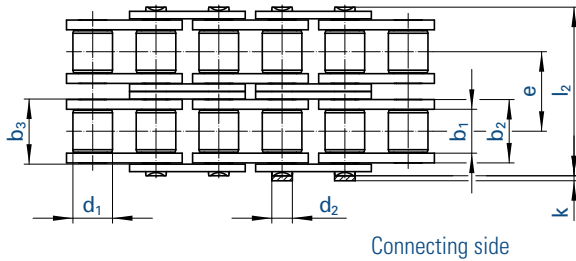

Triplex chains

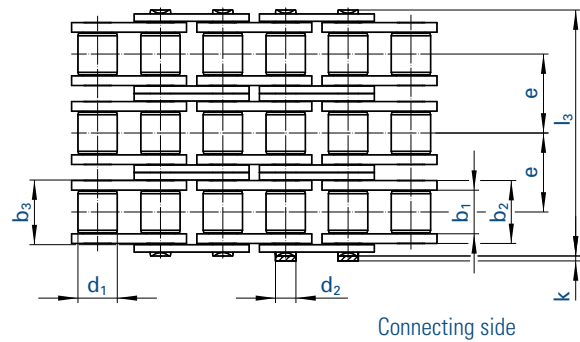

Chain		ISO	Pitch		Inner width b_1 min.	Inner link width b_2 max.	Outer plate width b_3 min.	Roller \varnothing d_1 max.	Pin \varnothing d_2 max.	Transverse pitch e	Plate height g max.	Projection over connecting link k max.	Width over pin l max.	Bearing area f	Breaking load F_B min.	Weight q \approx	Connecting links No.
No.	Ind.		mm	inch													
462 RF MA	08 B-1	12,700	1/2	7,75	11,30	11,43	8,51	4,45	-	11,8	3,9	17,0	0,50	12,00	0,70	4,7,11,12,15	
501 RF MA	10 B-1	15,875	5/8	9,65	13,28	13,41	10,16	5,08	-	14,7	4,1	19,6	0,67	14,50	0,91	4,7,11,12,15	
513 RF MA	12 B-1	19,050	3/4	11,68	15,62	15,75	12,07	5,72	-	16,1	4,6	22,7	0,89	18,50	1,18	4,7,11,12,15	
548 RF MA	16 B-1	25,400	1	17,02	25,40	25,60	15,88	8,28	-	21,0	5,4	36,1	2,10	40,00	2,50	4,7,11,12	
D 462 RF MA	08 B-2	12,700	1/2	7,75	11,30	11,43	8,51	4,45	13,92	11,8	3,9	31,0	1,01	20,40	1,36	4,7,11,12,15	
D 501 RF MA	10 B-2	15,875	5/8	9,65	13,28	13,41	10,16	5,08	16,59	14,7	4,1	36,2	1,34	24,65	1,82	4,7,11,12,15	
D 513 RF MA	12 B-2	19,050	3/4	11,68	15,62	15,75	12,07	5,72	19,46	16,1	4,6	42,2	1,79	31,45	2,38	4,7,11,12,15	
D 548 RF MA	16 B-2	25,400	1	17,02	25,40	25,60	15,88	8,28	31,88	21,0	5,4	68,0	4,21	68,00	5,10	4,7,11,12	
T 462 RF MA	08 B-3	12,700	1/2	7,75	11,30	11,43	8,51	4,45	13,92	11,8	3,9	44,9	1,51	32,50	2,01	4,7,11,12,15	
T 501 RF MA	10 B-3	15,875	5/8	9,65	13,28	13,41	10,16	5,08	16,59	14,7	4,1	52,8	2,02	39,00	2,70	4,7,11,12,15	
T 513 RF MA	12 B-3	19,050	3/4	11,68	15,62	15,75	12,07	5,72	19,46	16,1	4,6	61,7	2,68	49,50	3,12	4,7,11,12,15	
T 548 RF MA	16 B-3	25,400	1	17,02	25,40	25,60	15,88	8,28	31,88	21,0	5,4	99,9	6,31	108,00	7,50	4,7,11,12	

Can also be supplied with attachments, straight plates (type series GL) and as double pitch roller chains (dimensions according to ISO 1275). Chains 548 available as type series GLs with plate height $g = 21$ mm (max.) and as type series GL with $g = 24$ mm (max.). Sprockets on request.

Connecting links: According to ISO (...)

